

Dell Precision 7920 Tower

Owner's Manual



Notes, cautions, and warnings

 | **NOTE:** A NOTE indicates important information that helps you make better use of your product.

 | **CAUTION:** A CAUTION indicates either potential damage to hardware or loss of data and tells you how to avoid the problem.

 | **WARNING:** A WARNING indicates a potential for property damage, personal injury, or death.

© 2017 2018 Dell Inc. or its subsidiaries. All rights reserved. Dell, EMC, and other trademarks are trademarks of Dell Inc. or its subsidiaries. Other trademarks may be trademarks of their respective owners.

1 Working on your computer.....	7
Safety instructions.....	7
Turning off your computer — Windows 10.....	7
Before working inside your computer.....	8
After working inside your computer.....	8
2 Removing and installing components.....	9
Screw size list.....	9
Recommended tools.....	10
Power supply unit (PSU).....	11
Removing the PSU.....	11
Installing the PSU.....	11
Side cover.....	11
Removing the side cover.....	11
Installing the side cover.....	13
Air shroud.....	13
Removing the air shroud.....	13
Installing the air shroud fan assembly.....	13
Removing the air shroud fan.....	14
Installing the air shroud fan.....	15
Front bezel.....	15
Removing the front bezel.....	15
Installing the front bezel.....	17
PCIe holder.....	17
Removing PCIe card holder	17
Installing the PCIe card holder.....	18
Intrusion switch.....	18
Removing the intrusion switch.....	18
Installing the intrusion switch.....	20
Front system fan assembly.....	21
Removing the front system fan assembly.....	21
Installing the front system fan assembly.....	24
Internal chassis speaker.....	24
Removing the internal chassis speaker.....	25
Installing the internal chassis speaker.....	26
Hard disk drive and the Optical disk drive bezel.....	26
Removing the HDD bezel.....	26
Installing the HDD bezel.....	27
Hard disk drive assembly.....	27
Removing the HDD carrier.....	27
Installing the HDD carrier.....	28
Removing the HDD.....	28
Installing the HDD.....	29

Front input and output bezel.....	30
Removing the front input and output bezel.....	30
Installing the front input and output bezel.....	31
Front input and output panel.....	31
Removing the front input and output panel.....	31
Installing the front input and output panel.....	34
Removing the input and output panel bracket.....	35
Installing the input and output panel bracket.....	36
Rear system fan.....	36
Removing the rear system fan.....	36
Installing the rear system fan.....	38
Right side cover.....	38
Removing the right side cover.....	38
Installing the right side cover.....	38
Slim Optical Disk Drive.....	39
Removing the slim ODD and ODD latch.....	39
Installing the slim ODD and ODD latch.....	41
Power distribution and fan control board.....	41
Removing the power distribution and fan control board.....	41
Installing the power distribution and fan control board.....	42
Front HDD cable and fan assembly.....	43
Removing the front HDD cable and fan assembly.....	43
Installing the front HDD cable and fan assembly.....	44
Fan bracket.....	44
Removing the fan from the fan bracket.....	44
Installing the fan into the fan bracket.....	45
Graphical processing unit(GPU).....	46
Removing the GPU.....	46
Installing the GPU.....	47
Memory.....	47
Removing the memory module.....	47
Installing the memory module.....	48
Coin cell battery.....	48
Removing the coin cell battery.....	48
Processor heat sink module.....	50
Removing the processor heat sink module.....	50
Installing the processor heat sink module.....	51
Removing the CPU.....	51
Installing the CPU.....	53
System board.....	56
Removing system board.....	56
Installing the system board.....	59
System board components.....	59
3 Technology and components.....	62
Memory configuration.....	62
Technologies list.....	63



Teradici PCoIP.....	64
MegaRAID 9440-8i and 9460-16i controller.....	64
Key Features:.....	65
Expansion card installation guidelines.....	67
4 System specifications.....	69
System specifications.....	69
Memory specifications	69
Video specifications.....	70
Audio specifications.....	70
Network specifications.....	70
Card Slots.....	71
Storage specifications.....	71
External connectors.....	71
Power specifications.....	71
Physical specifications.....	72
Environmental specifications.....	72
5 System Setup.....	73
General options.....	73
System configuration.....	74
Video.....	76
Security.....	77
Secure boot.....	78
Performance.....	78
Power management.....	79
POST behavior.....	80
Virtualization support.....	80
Maintenance.....	81
System logs.....	81
Engineering configurations.....	81
Updating the BIOS in Windows	81
Updating BIOS on systems with bitlocker enabled.....	82
Updating your system BIOS using a USB flash drive.....	82
Updating the Dell BIOS in Linux and Ubuntu environments.....	83
Flashing the BIOS from the F12 One-Time boot menu.....	83
System and setup password.....	87
Assigning a system password and setup password.....	87
Deleting or changing an existing system setup password.....	88
6 Software.....	89
Supported operating system.....	89
Downloading drivers.....	89
Chipset driver.....	90
Graphics controller driver.....	90
USB drivers.....	90
Network drivers.....	91



Audio drivers.....	91
Ports.....	91
Storage controller drivers.....	91
Other drivers.....	91
Security device drivers.....	91
Software device drivers.....	92
Human Interface Devices.....	92
Portable Devices.....	92
7 Troubleshooting.....	93
Dell Enhanced Pre-Boot System Assessment — ePSA diagnostic 3.0.....	93
Running the ePSA diagnostics.....	93
Testing memory using ePSA.....	93
Preboot blinking power button codes.....	94
8 Contacting Dell.....	97



Working on your computer

Topics:

- Safety instructions
- Turning off your computer — Windows 10
- Before working inside your computer
- After working inside your computer

Safety instructions

Use the following safety guidelines to protect your computer from potential damage and to ensure your personal safety. Unless otherwise noted, each procedure included in this document assumes that the following conditions exist:

- You have read the safety information that shipped with your computer.
- A component can be replaced or, if purchased separately, installed by performing the removal procedure in reverse order.

- ⚠ WARNING:** Disconnect all power sources before opening the computer cover or panels. After you finish working inside the computer, replace all covers, panels, and screws before connecting to the power source.
- ⚠ WARNING:** Before working inside your computer, read the safety information that shipped with your computer. For additional safety best practices information, see the Regulatory Compliance Homepage at www.Dell.com/regulatory_compliance
- ⚠ CAUTION:** Many repairs may only be done by a certified service technician. You should only perform troubleshooting and simple repairs as authorized in your product documentation, or as directed by the online or telephone service and support team. Damage due to servicing that is not authorized by Dell is not covered by your warranty. Read and follow the safety instructions that came with the product.
- ⚠ CAUTION:** To avoid electrostatic discharge, ground yourself by using a wrist grounding strap or by periodically touching an unpainted metal surface at the same time as touching a connector on the back of the computer.
- ⚠ CAUTION:** Handle components and cards with care. Do not touch the components or contacts on a card. Hold a card by its edges or by its metal mounting bracket. Hold a component such as a processor by its edges, not by its pins.
- ⚠ CAUTION:** When you disconnect a cable, pull on its connector or on its pull-tab, not on the cable itself. Some cables have connectors with locking tabs; if you are disconnecting this type of cable, press in on the locking tabs before you disconnect the cable. As you pull connectors apart, keep them evenly aligned to avoid bending any connector pins. Also, before you connect a cable, ensure that both connectors are correctly oriented and aligned.
- ⓘ NOTE:** The color of your computer and certain components may appear differently than shown in this document.
- ⚠ CAUTION:** System will shut down if side covers are removed while the system is running. The system will not power on if the side cover is removed.

Turning off your computer — Windows 10

- ⚠ CAUTION:** To avoid losing data, save and close all open files and exit all open programs before you turn off your computer or remove the side cover.

- 1 Click or tap .
- 2 Click or tap  and then click or tap **Shut down**.



 **NOTE:** Ensure that the computer and all attached devices are turned off. If your computer and attached devices did not automatically turn off when you shut down your operating system, press and hold the power button for about 6 seconds to turn them off.

Before working inside your computer

To avoid damaging your computer, perform the following steps before you begin working inside the computer.

- 1 Ensure that you follow the [Safety Instruction](#).
- 2 Ensure that your work surface is flat and clean to prevent the computer cover from being scratched.
- 3 Ensure you follow the [Turning off your computer](#).
- 4 Disconnect all network cables from the computer.

 **CAUTION:** To disconnect a network cable, first unplug the cable from your computer and then unplug the cable from the network device.

- 5 Disconnect your computer and all attached devices from their electrical outlets.
- 6 Press and hold the power button while the computer is unplugged to ground the system board.

 **NOTE:** To avoid electrostatic discharge, ground yourself by using a wrist grounding strap or by periodically touching an unpainted metal surface at the same time as touching a connector on the back of the computer.

After working inside your computer

After you complete any replacement procedure, ensure that you connect any external devices, cards, and cables before turning on your computer.

- 1 Connect any telephone or network cables to your computer.

 **CAUTION:** To connect a network cable, first plug the cable into the network device and then plug it into the computer.

- 2 Connect your computer and all attached devices to their electrical outlets.
- 3 Turn on your computer.
- 4 If required, verify that the computer works correctly by running **ePSA diagnostics**.

Removing and installing components

Topics:

- Screw size list
- Recommended tools
- Power supply unit (PSU)
- Side cover
- Air shroud
- Front bezel
- PCIe holder
- Intrusion switch
- Front system fan assembly
- Internal chassis speaker
- Hard disk drive and the Optical disk drive bezel
- Hard disk drive assembly
- Front input and output bezel
- Front input and output panel
- Rear system fan
- Right side cover
- Slim Optical Disk Drive
- Power distribution and fan control board
- Front HDD cable and fan assembly
- Fan bracket
- Graphical processing unit(GPU)
- Memory
- Coin cell battery
- Processor heat sink module
- System board

Screw size list

Table 1. Screw list

Component	Screw Type	Quantity
PSU extended card	#6-32X1/4 inches	3
FIO board	#6-32X1/4 inches	2
Slim ODD cable for blind mate	M3X5.0mm	2
Slim ODD cable for blind mate with ODD bracket	#6-32 UNC X5.45mm	1
FIO bracket	#6-32X1/4 inches	1



Component	Screw Type	Quantity
Right Side Cover	#6-32 UNC X7.0mm	2
Up-Bottom air shroud	M3X5.0mm	3
Down-Bottom air shroud	M3X5.0mm	2
Motherboard	#6-32X1/4 inches	12
Front Fan Bracket-MB tray	#6-32X1/4 inches	2
Front Fan Bracket-Front wall	#6-32X1/4 inches	2
Intruder holder	#6-32X1/4 inches	1
Rear Fan bracket	#6-32X1/4 inches	2
Rear HDD cover	#6-32 UNC X7.0mm	2
Flex0 HDD bay bracket	#6-32 UNC X5.45mm	4
Flex0 6025fan bracket for cable attached	#6-32 UNC X5.45mm	2
Flex0 6025fan bracket for hot plug	#6-32 UNC X5.45mm	2
Flex0 and Flex1 HH ODD bracket	#6-32 UNC X5.45mm	4
Flex1 HDD bay bracket	#6-32 UNC X5.45mm	4
Flex1 6025fan bracket for cable attached	#6-32 UNC X5.45mm	2
Flex1 6025fan bracket for hot plug	#6-32 UNC X5.45mm	2
Flex2 HDD bay bracket	#6-32 UNC X5.45mm	4
Flex2 6025fan bracket for cable attached	#6-32 UNC X5.45mm	2
Flex3 HDD bracket	#6-32 UNC X5.45mm	4
Flex3 6025fan bracket for cable attached	#6-32 UNC X5.45mm	2
Flex4 HDD bracket	#6-32 UNC X5.45mm	4
Flex4 6025fan bracket for cable attached	#6-32 UNC X5.45mm	2
HH ODD holder	M3X5.0mm	4
HSBP board	#6-32 UNC X5.45mm	3
CPU0 cooler/CPU0 Liquid Cooler	T-30 torx bolt	4
CPU1 cooler/CPU1 Liquid Cooler	T-30 torx bolt	4
Liquid Cooler Bracket	#6-32 UNC X5.45mm	12

Recommended tools

The procedures in this document require the following tools:

- Phillips #0 screwdriver
- Phillips #1 screwdriver
- Philips #2 screwdriver
- Plastic scribe
- T-30 torx screwdriver

① | **NOTE:** The #0 screw driver is for screws 0-1 and the #1 screw driver is for screws 2-4

Power supply unit (PSU)

Removing the PSU

- 1 Follow the procedure in [Before working inside your computer](#).
- 2 Disconnect the power cable from the system.
- 3 Press the PSU release latch [1] and slide the power supply away from the system [2].

① | **NOTE:** If the PSU cannot be removed then remove the right side cover of the system and check if the PSU is secured with a screw.



Installing the PSU

- 1 Slide in the power supply unit to the PSU slot on the system.
- 2 Connect the power cable to the system.
- 3 Follow the procedure in [After working inside your computer](#)

Side cover

Removing the side cover

- 1 Follow the procedure in [Before working inside your computer](#).



CAUTION: The system will not power on while the side cover is off. Also, the system will shut down if the side cover is removed while the system is on.

- 2 To remove the side cover:
- 3 Press the latch



- 4 Pull the latch [1] upward and rotate it to release the cover [2].

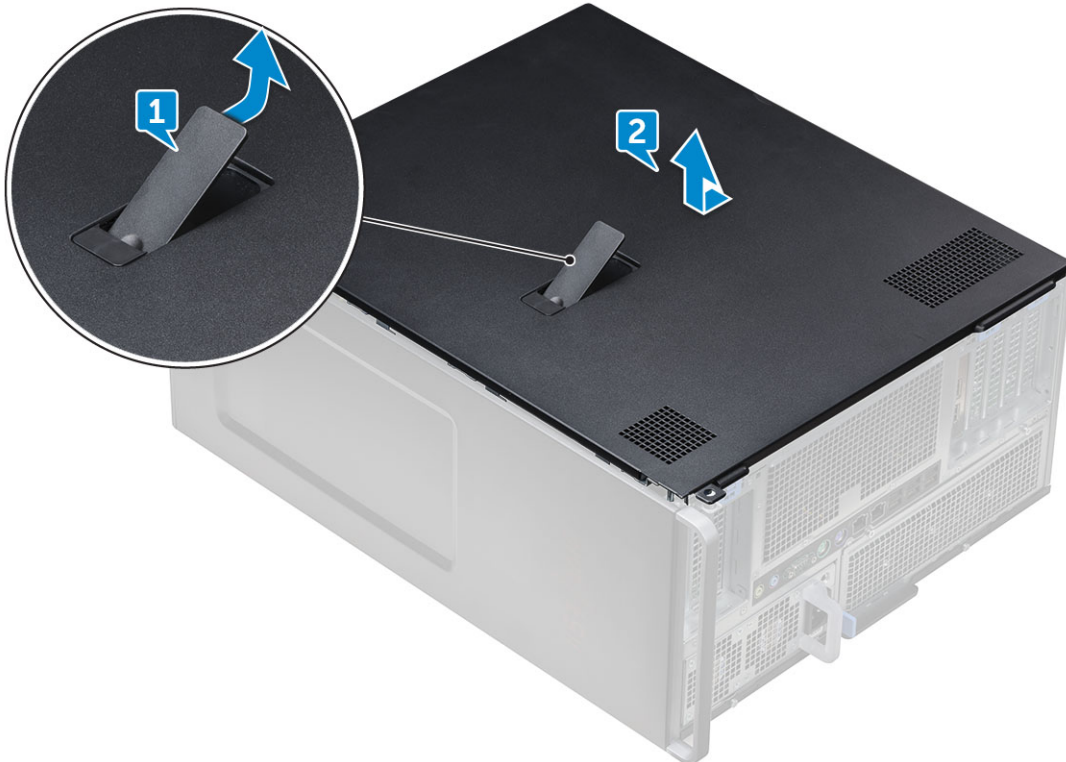

- 5 Lift the cover to remove it from the system.

Installing the side cover

- 1 First hold and align the bottom of the side cover to the chassis.
- 2 Ensure that the hook on the bottom of the side cover snaps into the notch on the system.
- 3 Press the system cover until it clicks into place.

CAUTION: The system will not power on without the side cover. Also, the system will shut down if the side cover is removed while the system is on.

- 4 Follow the procedure in [After working inside your computer](#) .

Air shroud

Removing the air shroud

- 1 Follow the procedure in [Before working inside your computer](#).
- 2 Remove the [side cover](#).
- 3 To remove the air shroud Fan assembly:
 - a Disconnect the fan connector cable from the system board [1].
 - b Lift the shroud away from the system [2].

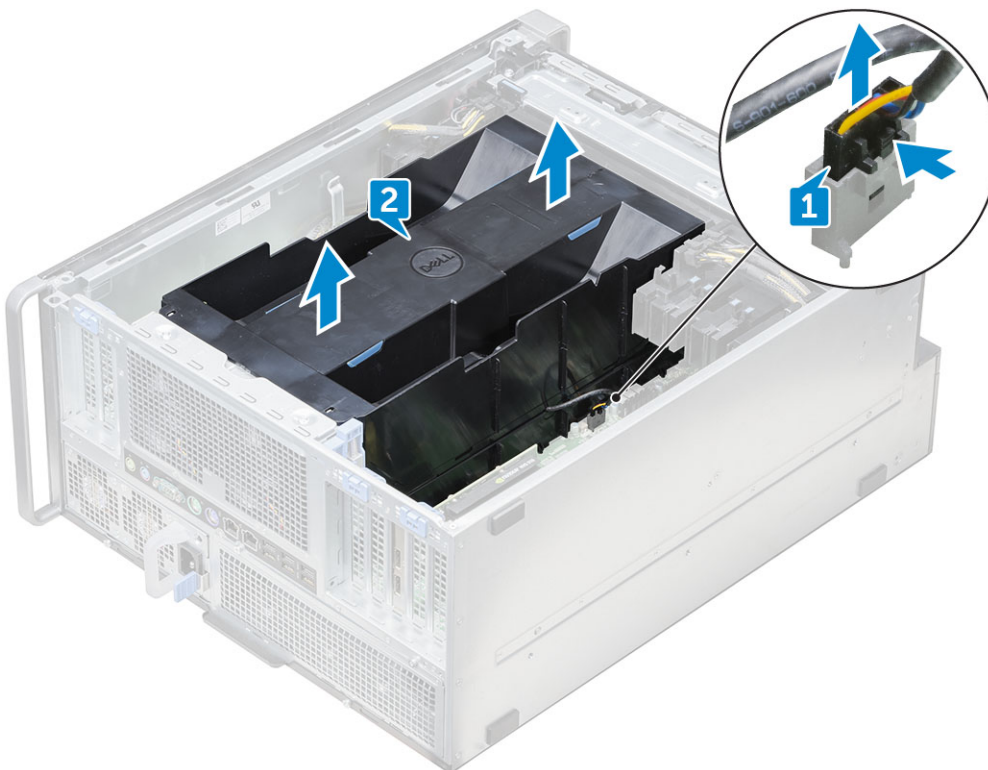

Installing the air shroud fan assembly

- 1 Place the shroud into its position and ensure that the tab fits into the system.
- 2 Press down the shroud until it locks with a click.
- 3 Reconnect the fan connector cable to the system board.



- 4 Install the [side cover](#).
- 5 Follow the procedure in [After working inside your computer](#).

Removing the air shroud fan

- 1 Follow the procedure in [Before working inside your computer](#).
- 2 Remove the:
 - a [side cover](#)
 - b [removing air shroud \(Top\)](#)
- 3 To see the fan flip-over the shroud.
- 4 To remove the fan, release the fan connector cable from the latches [1] and [2].

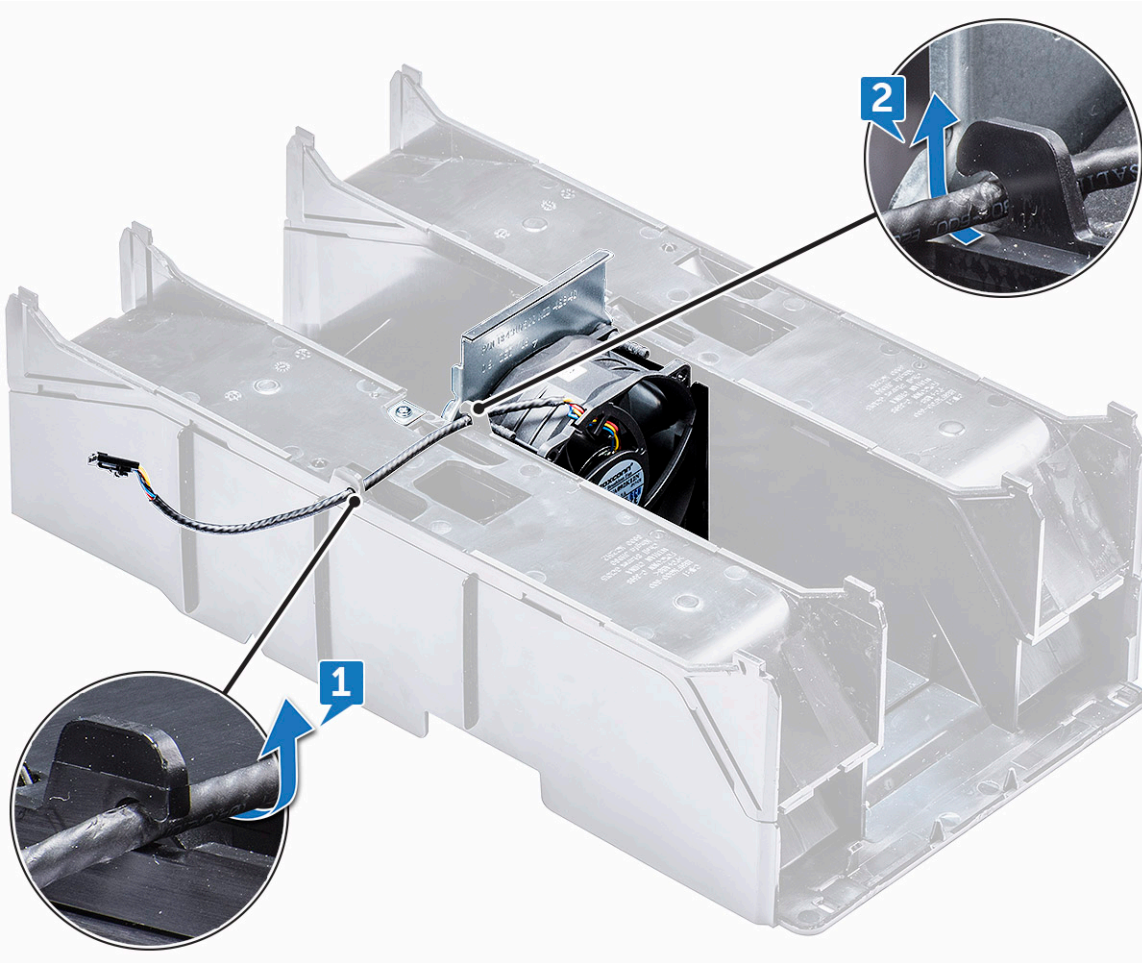

- 5 Remove the screws that secures the fan to the air shroud [1], and lift the fan away from the air shroud [2].

NOTE: The shroud will need to be flexed open slightly in order to be removed.

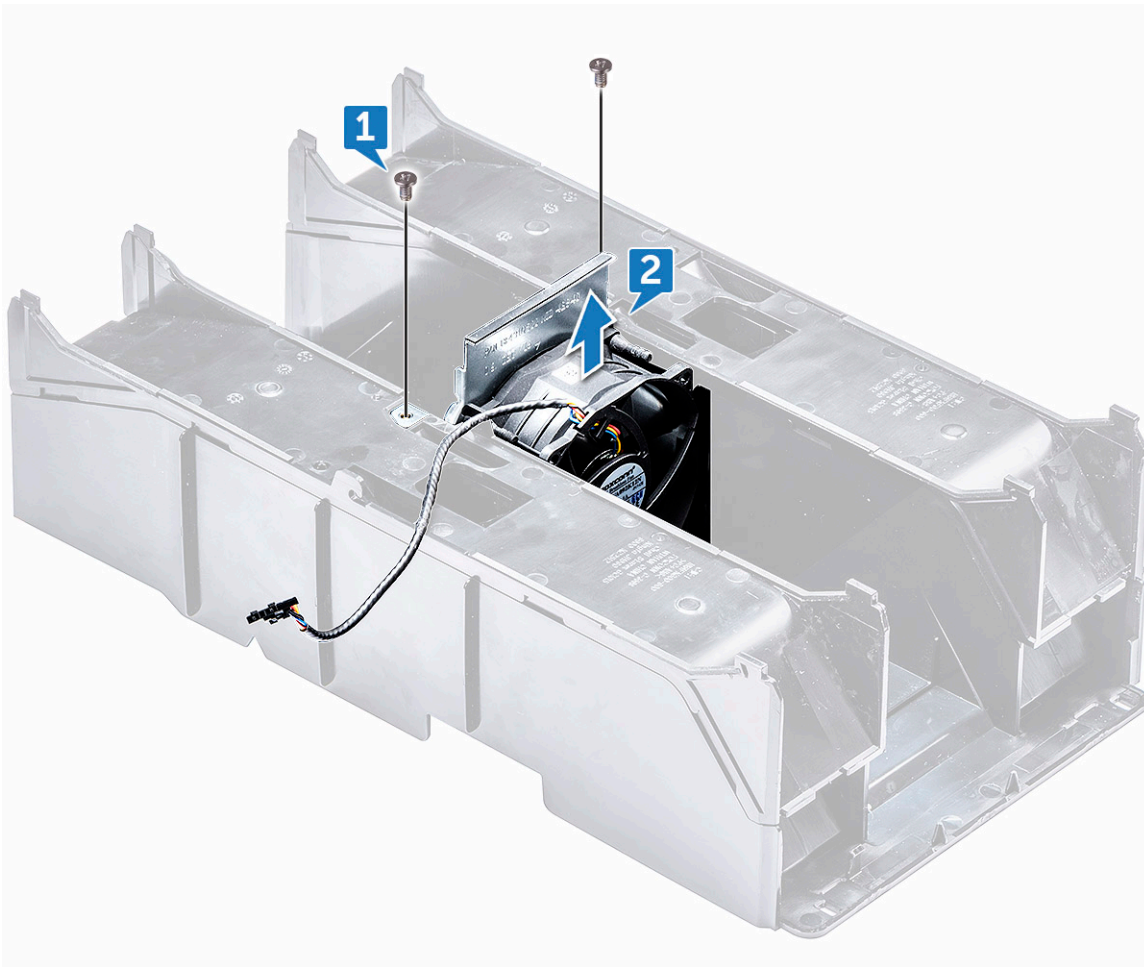

Installing the air shroud fan

- 1 Place the fan into its position inside the air shroud .
- 2 Replace the screws that secure the fan to the air shroud.
- 3 Route back the fan connector cable through the latches on the air shroud and flip over.
- 4 Install the:
 - a [air shroud \(top\)](#)
 - b [side cover](#)
- 5 Follow the procedure in [After working inside your computer](#).

Front bezel

Removing the front bezel

- 1 Follow the procedure in [Before working inside your computer](#).
- 2 Remove the [side cover](#).
- 3 To remove the front bezel:
 - a Pry the retention tabs to release the front bezel from the system.





b Rotate the bezel forward and lift the front bezel away from the system.



Installing the front bezel

- 1 Hold the bezel and ensure that the hooks on the bezel snap into the notches on the system.
- 2 Rotate the bezel forward and press the front bezel until the tabs click into place.
- 3 Follow the procedure in [After working inside your computer](#).

PCIe holder

Removing PCIe card holder

- 1 Follow the procedure in [Before working inside your computer](#).
- 2 Remove the following:
 - a [side cover](#)
 - b [air shroud](#)
- 3 To remove the PCIe card holder:

NOTE: If full length cards are installed, you will need to remove these cards before removing the holder.

NOTE: If MegaRAID 9460 is installed, disconnect the Super CAP from the card before removing the PCIe card holder from the system.

- a Disconnect the power cables on either side of the card holder by pressing the tab and pulling it out of the cable slot in the PCIe holder [1] and [2].
- b Release the dual cables passing through the clip on the card holder [3].

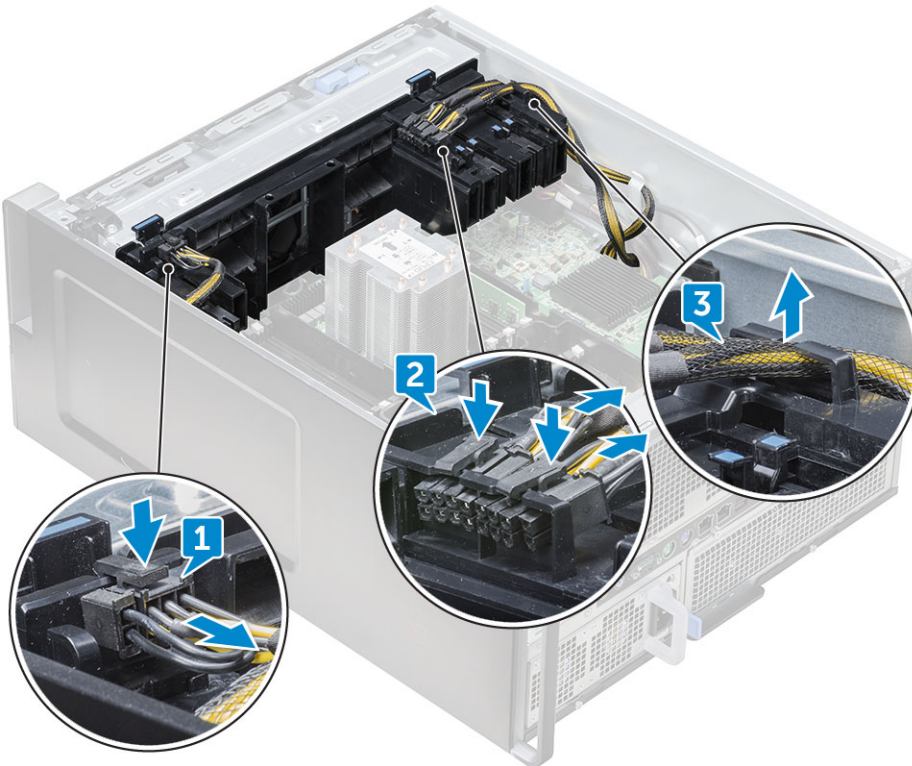

- 4 Release the latches connecting the front system fan assembly, and lift the PCIe card holder away from the chassis.

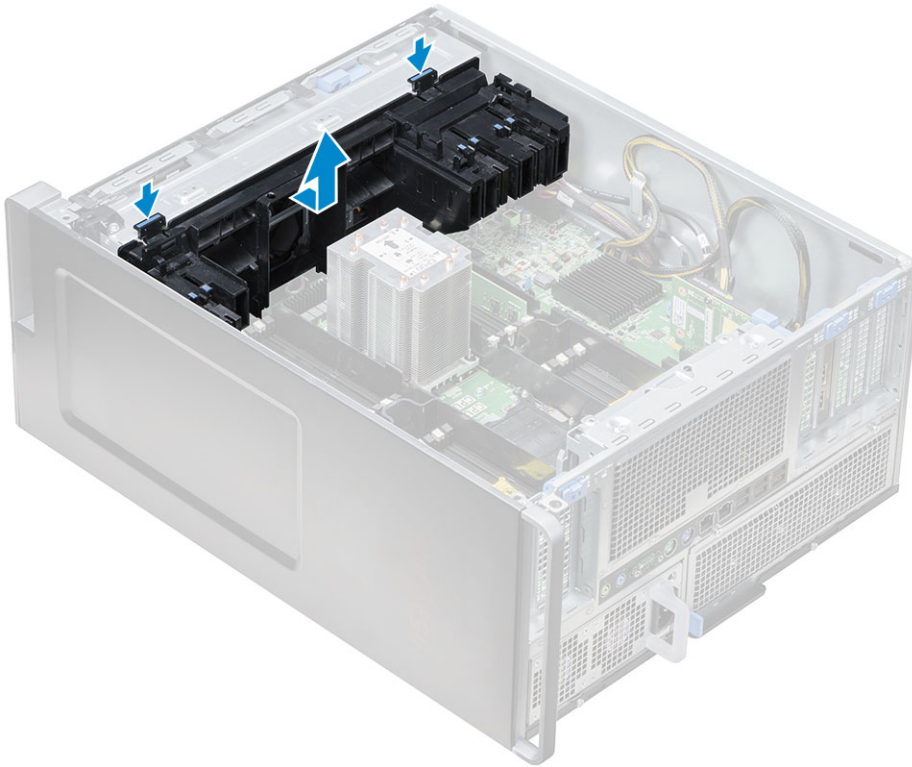

Installing the PCIe card holder

- 1 Align the PCIe card holder to the slot in front of the system fan assembly, and press down until it clicks in place.
- 2 Route the dual cables back through the clip on the PCIe card holder.
- 3 Connect the power cables on either side to the cable slots in the PCIe card holder.
- 4 Reinstall the full length cards if they were removed.
- 5 If the MegaRAID 9460 was removed, please connect the Super CAP back to the card.
- 6 Install the:
 - a [air shroud](#)
 - b [side cover](#)
- 7 Follow the procedure in [After working inside your computer](#).

Intrusion switch

Removing the intrusion switch

- 1 Follow procedure in [Before working inside your computer](#).
- 2 Remove the [right side cover](#).
- 3 To remove the intrusion switch that is located at the bottom of the system board:

NOTE: The system will not power on when the intrusion switch is uninstalled.

- a Press the knob of the intrusion switch toward the bottom of the chassis [1, 2].
- b Pull the intrusion switch down to remove it from the slot [3].

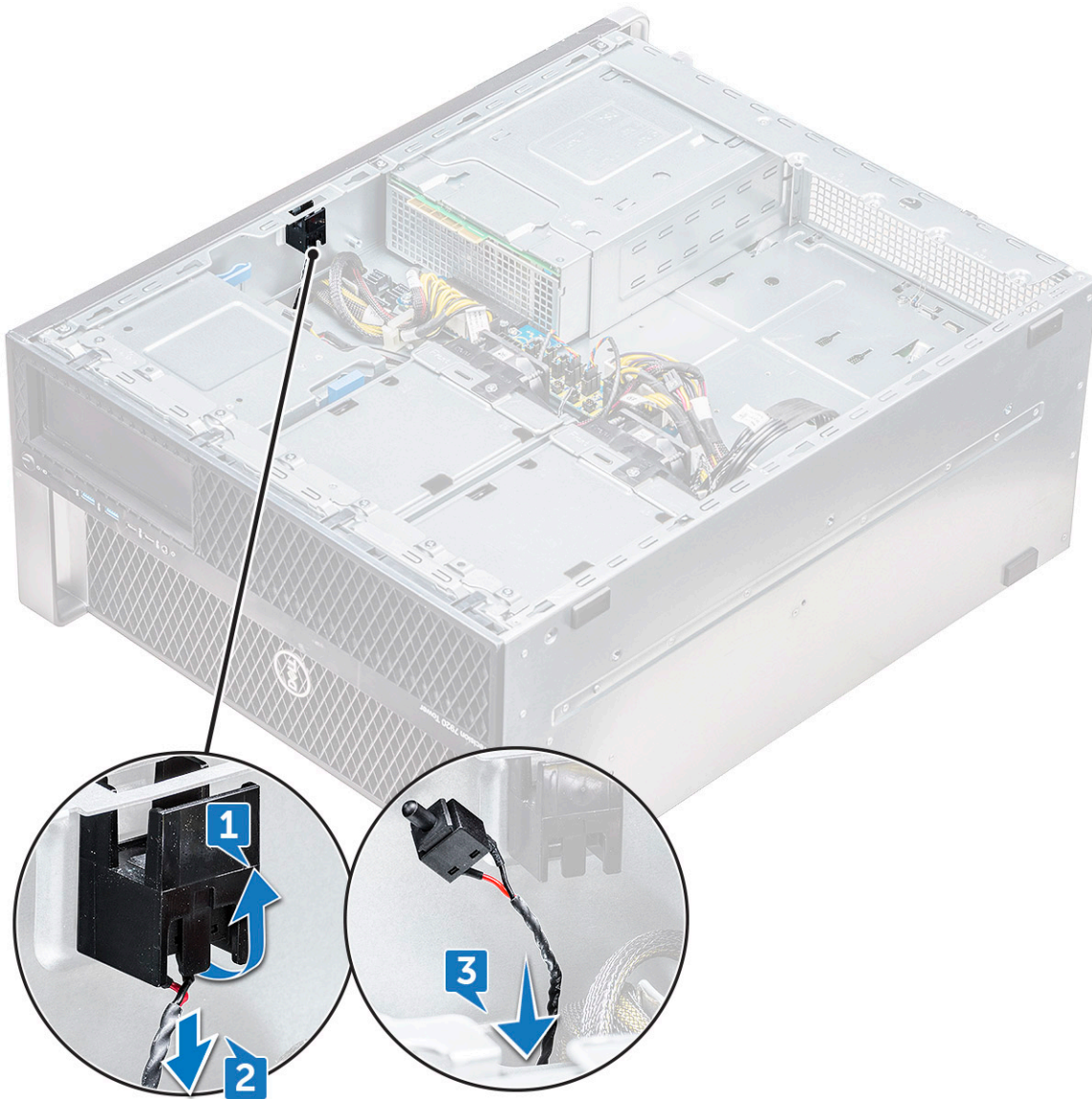

- 4 Install the [right side cover](#)
- 5 Flip the system back with the system cover facing up where the release latch is available.
- 6 Remove the following components :
 - a [side cover](#)
 - b [air shroud](#)
 - c [PCIe card holder](#)
- 7 To remove the intrusion switch module:
 - a Pull the bottom intrusion switch cable up toward the chassis [1].
 - b Press the tab to disconnect the intrusion switch cable from the system board [2].
 - c Unroute the intrusion switch cables from the clip on the chassis [3].
 - d Remove the screw on the intrusion module [4].
 - e Lift the intrusion module from the front system fan assembly [5].

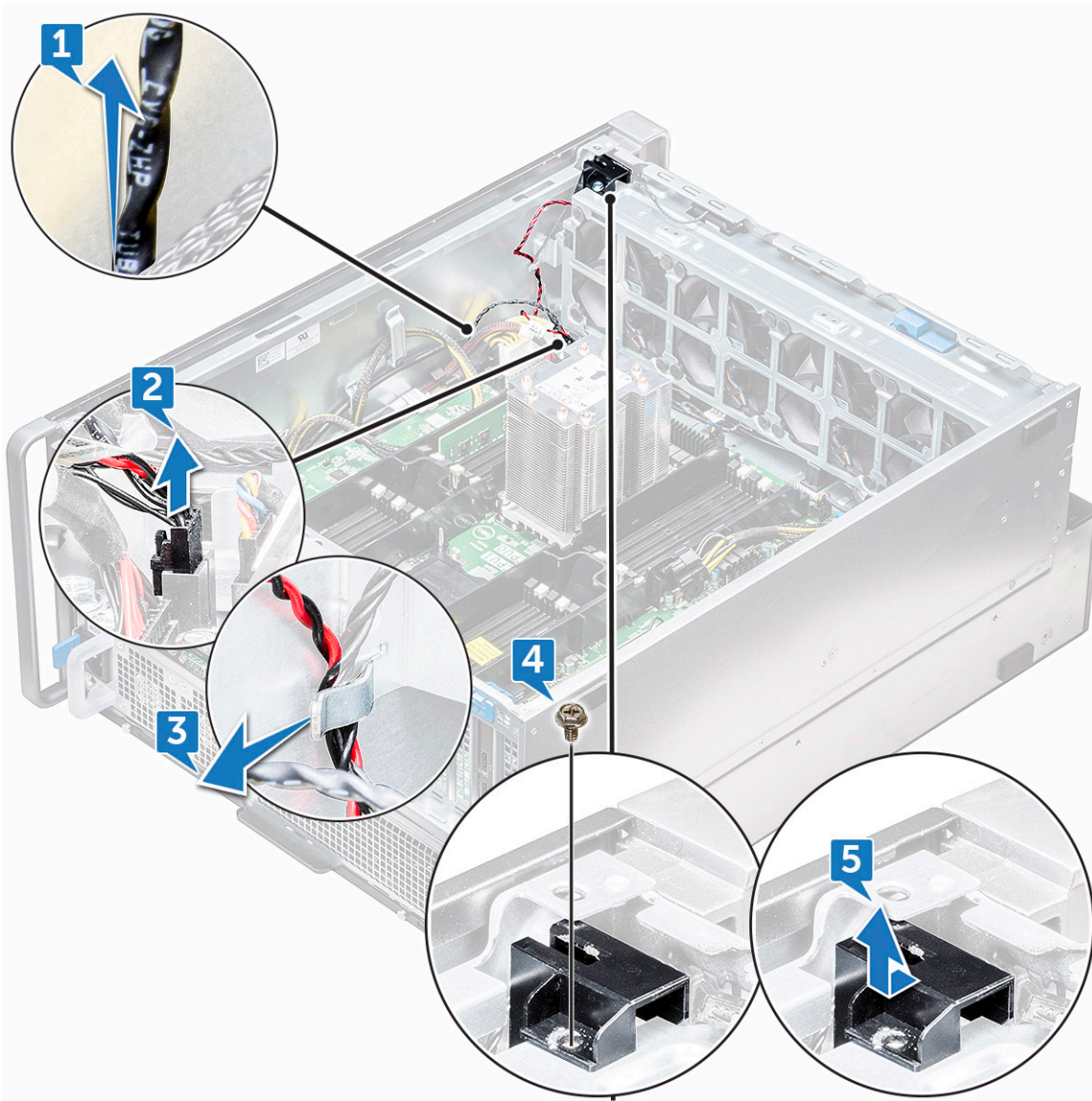

Installing the intrusion switch

- 1 Place the intrusion switch module into the slot in the front system fan assembly.
- 2 To secure the intrusion switch module to the front system fan chassis, replace the single screw on the module.
- 3 Route the intrusion switch cables through the clip on the chassis.
- 4 Connect the intrusion switch cable to the system board.
- 5 Push the bottom intrusion switch cable down toward the bottom chassis.
- 6 Replace the following components:
 - a [PCIe graphics card holder](#)
 - b [air shroud](#)
 - c [side cover](#)
- 7 Remove the [right side cover](#).
- 8 Pull the intrusion switch cable up from the top chassis.
- 9 Insert and slide the intrusion switch into the slot in the chassis to secure it.
- 10 Follow the procedure in [After working inside your computer](#).

Front system fan assembly

Removing the front system fan assembly

- 1 Follow the procedure in [Before working inside your computer](#).
- 2 Remove the following:
 - a [side cover](#)
 - b [front bezel](#)
 - c [air shroud](#)
 - d [PCIe card holder](#)
- 3 To remove the system fan assembly:
 - a Remove the single screw on the intrusion switch module [1], and lift it away from the system fan chassis [2].
 - b Disconnect the internal chassis speaker cable from the connector, unroute it from the clip on the system fan chassis [3], and lift it away from chassis [4].

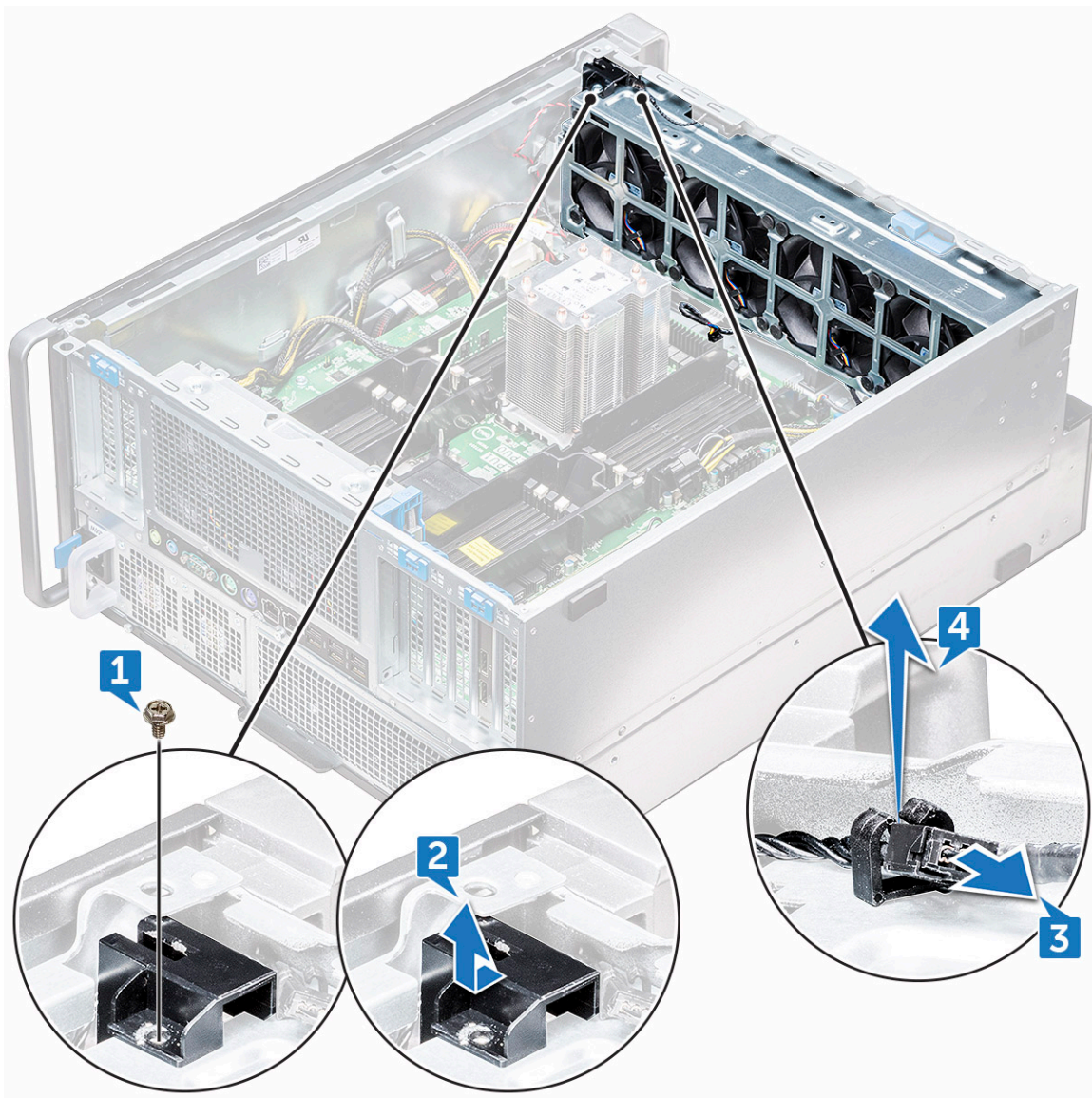

- 4 Disconnect the four system fan cables from the connectors on the system board.



CAUTION: Do not pull the connector by the cable wires. Instead, disconnect the cable by pulling on the connector end. Pulling the cable wires may loosen them from the connector.

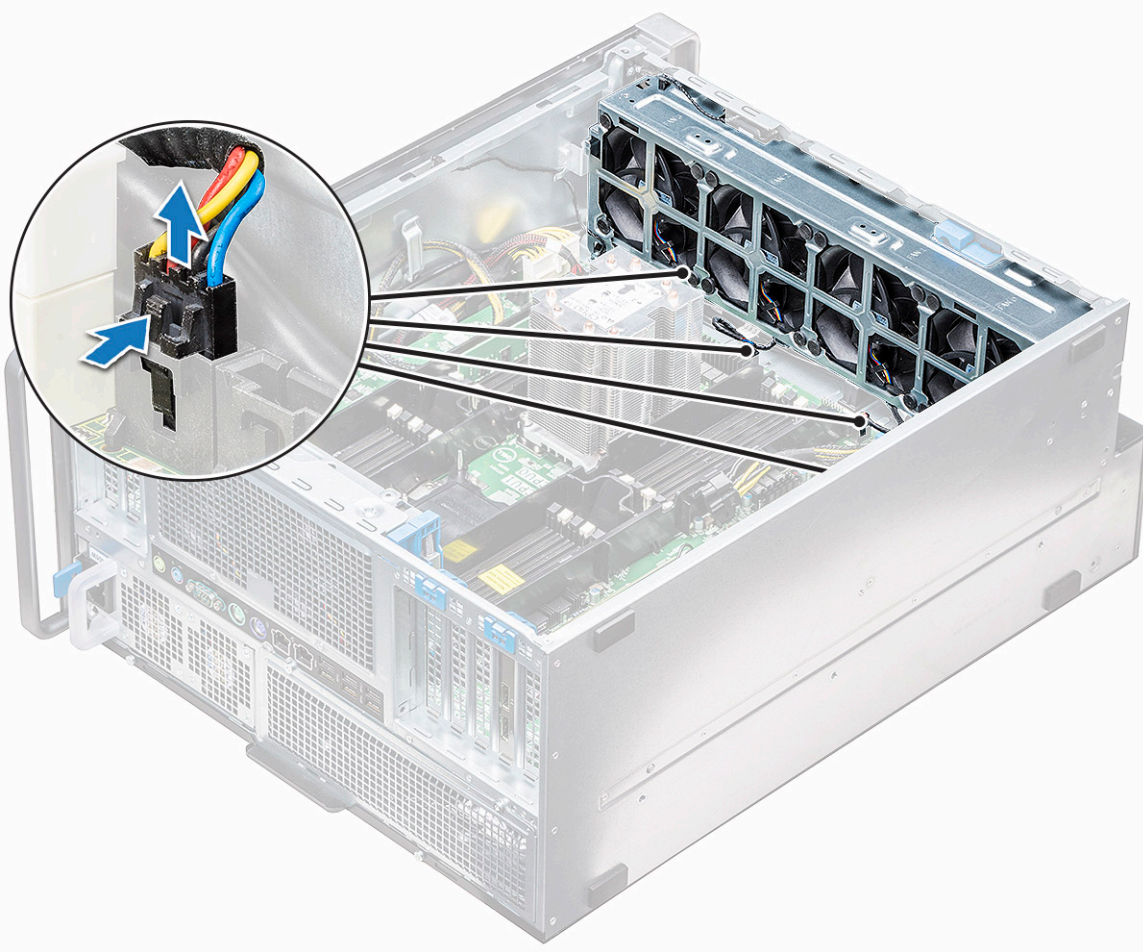

- 5 Remove the two screws securing the fan chassis to the system [1], and the two screws securing the fan chassis in front of the system [2].

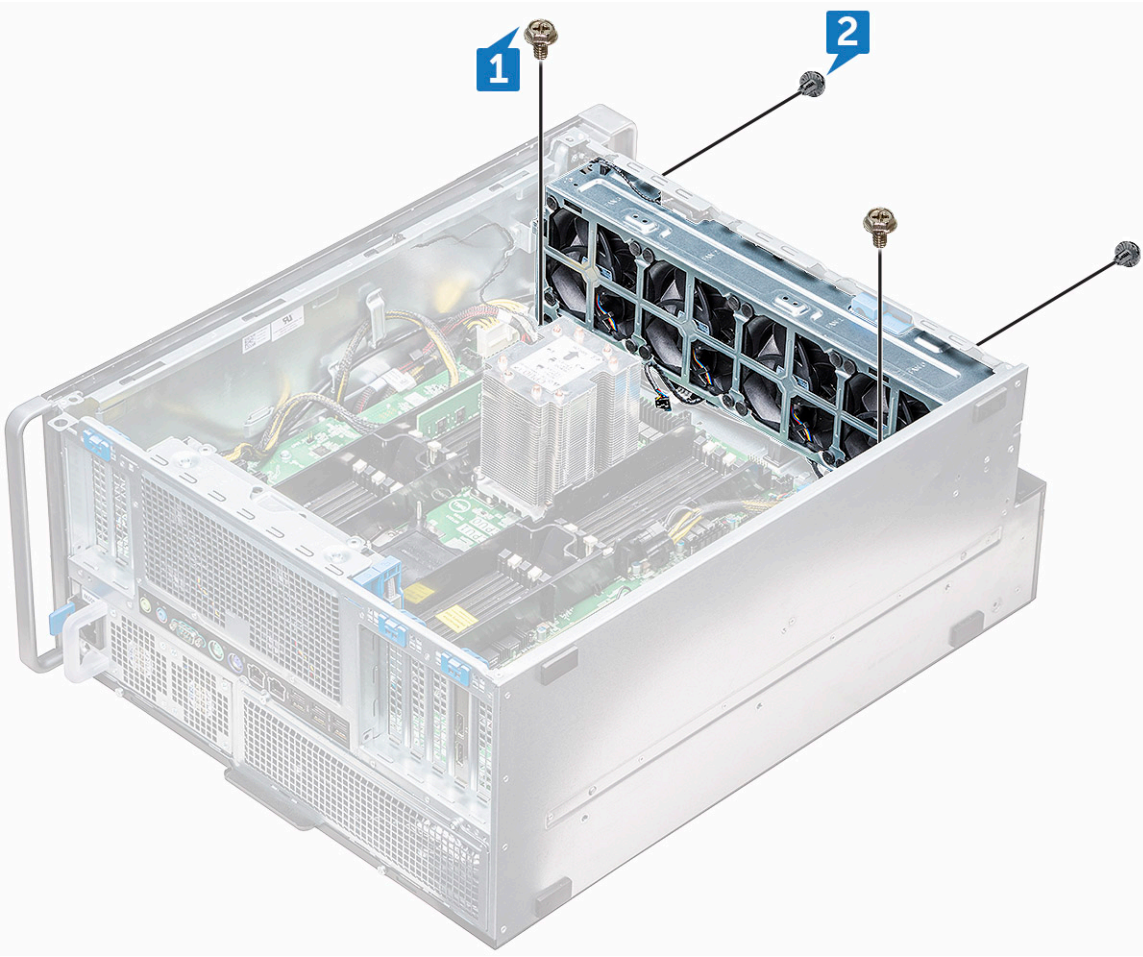

6 Rotate and lift the fan assembly away from the system.

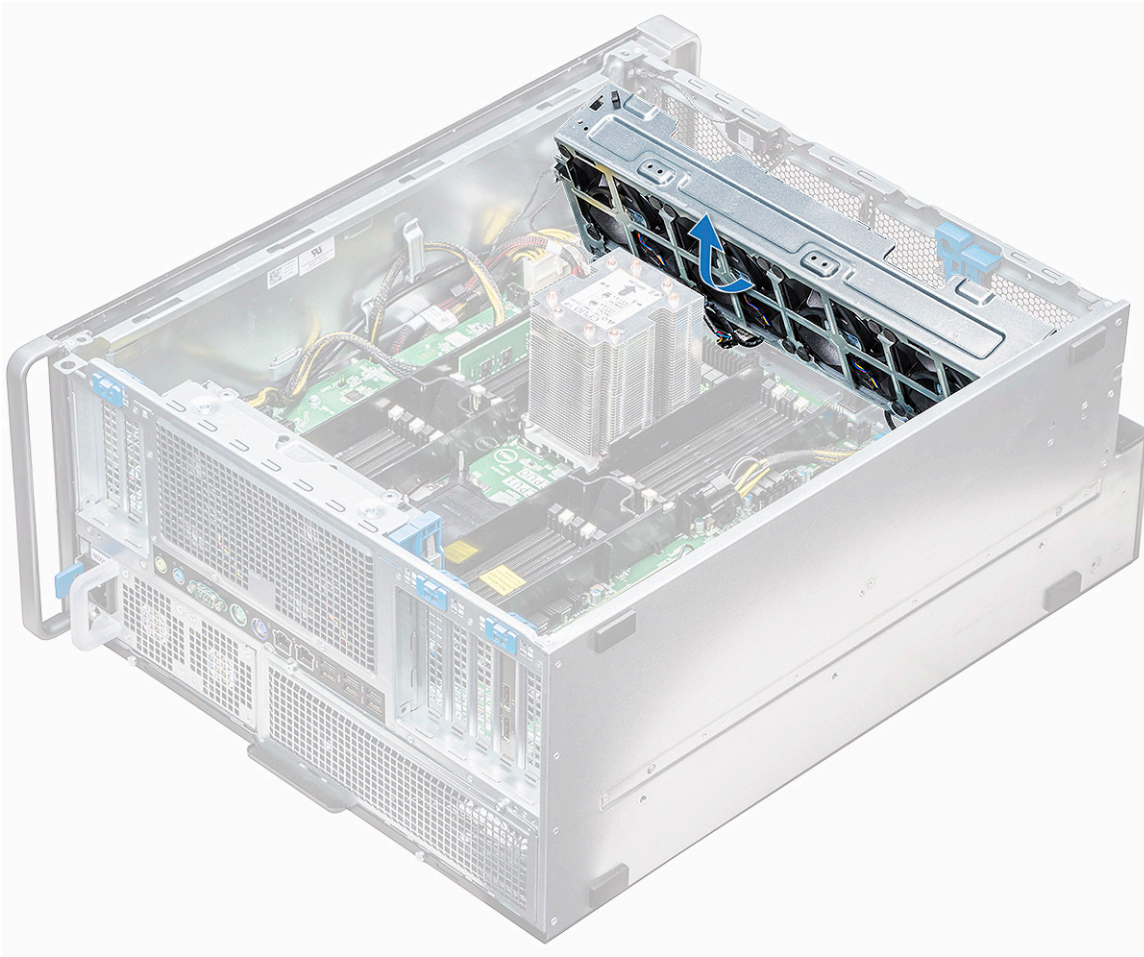

Installing the front system fan assembly

- 1 Hold the system fan by the sides with the cable end facing the bottom of the chassis.
- 2 Replace the two screws securing the system fan assembly in front of the system.
- 3 Replace the two screws securing the system fan assembly in the system.
- 4 Connect the four system fan cables to the system board.
- 5 Route back the internal chassis speaker cable through the clip on the system fan assembly, and connect the internal chassis speaker to the connector.
- 6 Replace the intrusion switch module to the slot on the fan assembly and insert the screw to secure it with the system fan assembly.
- 7 Install the following components:
 - a [PCIe graphics card holder](#)
 - b [air shroud](#)
 - c [front bezel](#)
 - d [side cover](#)
- 8 Follow the procedure in [After working inside your computer](#).

Internal chassis speaker

Removing the internal chassis speaker

- 1 Follow the procedure in [Before working inside your computer](#).
- 2 Remove the following:
 - a [side cover](#)
 - b [front bezel](#)
 - c [air shroud](#)
- 3 To remove the internal chassis speaker:
 - a Disconnect one end of the internal chassis speaker cable from the connector on the system fan assembly [1].
 - b Unroute the internal chassis speaker cable from the clip on the system fan assembly.
- 4 Press and hold the tabs [2] on either side of the internal chassis speaker, to slide and remove it out of the system [3].

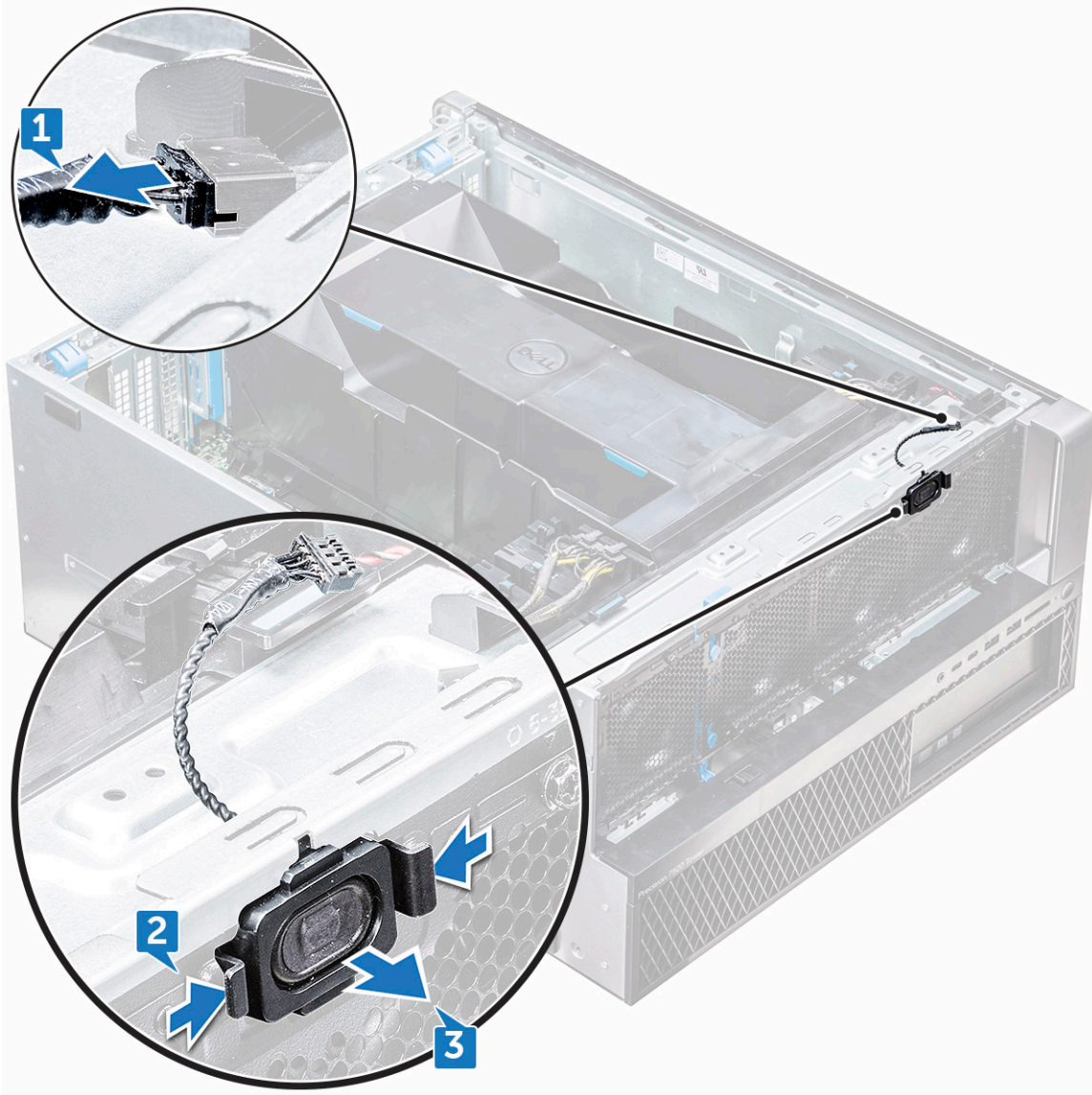

Installing the internal chassis speaker

- 1 Press and hold the tabs on either side of the internal chassis speaker, and slide the speaker module into the slot to secure it to the system.
- 2 Route the internal chassis speaker cable through the clip on the system fan assembly.
- 3 Connect the one end of the internal chassis speaker cable to the connector on the system fan assembly.
- 4 Install the following components:
 - a [air shroud](#)
 - b [front bezel](#)
 - c [side cover](#)
- 5 Follow the procedure in [After working inside your computer](#)

Hard disk drive and the Optical disk drive bezel

Removing the HDD bezel

- 1 Follow the procedure in [Before working inside your computer](#).
- 2 Remove the following components:
 - a [side cover](#)
 - b [front bezel](#)
- 3 To remove the HDD bezel:
 - a Press the blue unlock button [1], which is located near the front system fan assembly.
 - b Slide the latch [2] on the front I/O bezel, to release the HDD bezel from the chassis [3].

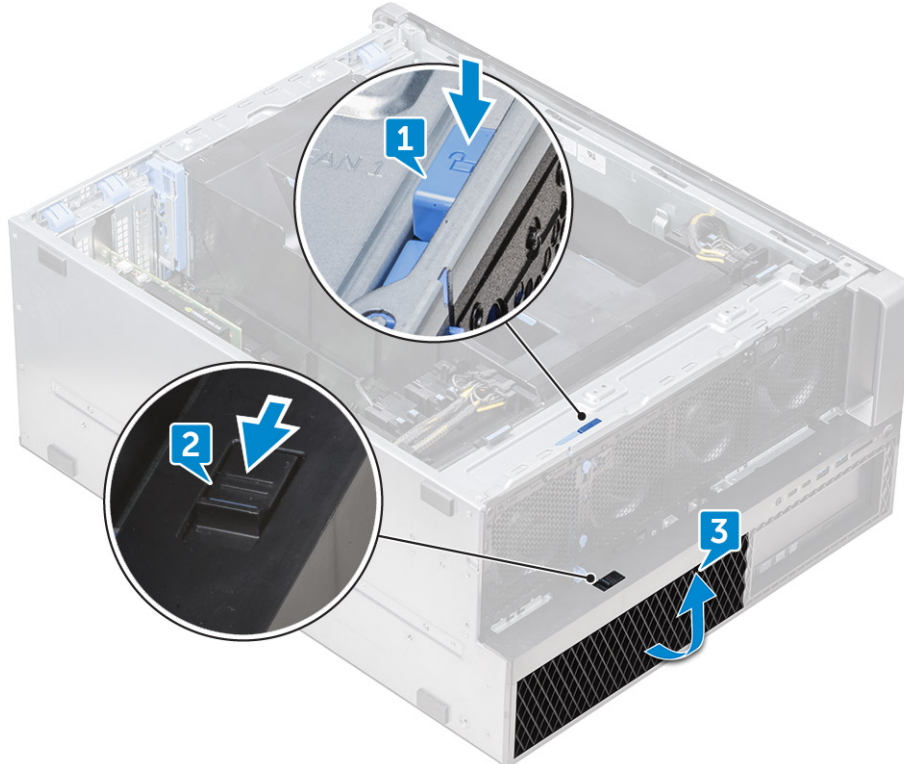

- c Rotate and lift the HDD bezel out from the chassis [3].
- 4 Optional: Remove the ODD bezel next to the HDD bezel from the chassis by prying the edges of the bezel and lifting it away.

Installing the HDD bezel

- 1 If the ODD bezel is removed, install it by aligning the notch of the bezel into the slot on the chassis.(Optional)
- 2 Align the HDD bezel onto its slots on the chassis and press the HDD bezel towards the chassis.
- 3 Press the blue lock button located near the front system fan assembly, to secure the HDD bezel to the chassis.
- 4 Install the following components:
 - a front bezel
 - b side cover
- 5 Follow the procedure in [After working inside your computer](#)

Hard disk drive assembly

Removing the HDD carrier

- 1 Follow the procedure in [Before working inside your computer](#).
- 2 Remove the:
 - a side cover

NOTE: Do not remove the side cover, if the front I/O bezel is unlocked.

 - b HDD and ODD bezel

NOTE: Remove only the HDD bezel.
- 3 To remove the HDD carrier:
 - a Press the release button [1] to unlock the latch [2].

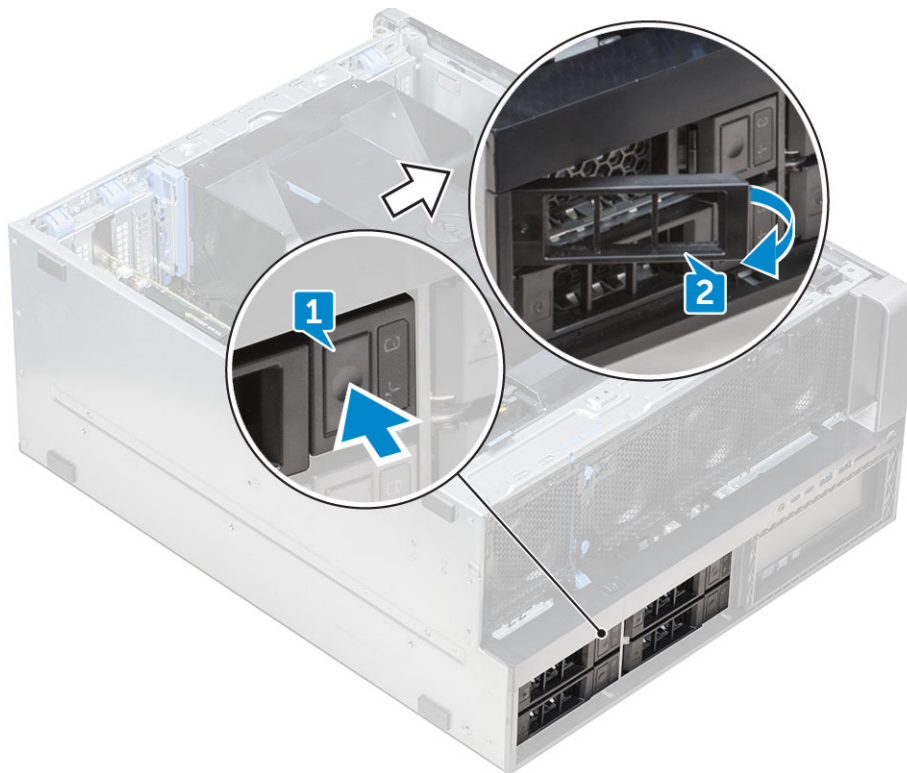

- b Pull the latch to slide the bracket out of the HDD slot.





Installing the HDD carrier

- 1 Slide the bracket into the drive bay until it clicks into place.
 - ⚠ CAUTION:** Ensure that the latch is open before installing the bracket.
- 2 Lock the latch.
- 3 Install the following components:
 - a [HDD and ODD bezel](#)
 - b [side cover](#)
- 4 Follow the procedure in [After working inside your computer](#).

Removing the HDD

- 1 Follow the procedure in [Before working inside your computer](#).
- 2 Remove the following:
 - a [side cover](#)
 - b [HDD and ODD bezel](#)
 - c [HDD bracket](#)
- 3 To remove the HDD:
 - a Expand one side of the bracket.



b Lift the hard drive out of the bracket.



Installing the HDD

- 1 Insert the HDD into the 3.5" bracket with the connector end of the hard drive towards the back of the HDD bracket.
- 2 Slide the HDD bracket back into the hard drive bay.



- 3 Install the following:
 - a HDD bracket
 - b HDD and ODD bezel
 - c side cover
- 4 Follow the procedure in [After working inside your computer](#)

Front input and output bezel

Removing the front input and output bezel

- 1 Follow the procedure in [Before working inside the computer](#).
- 2 Remove the:
 - a side cover
 - b front bezel
 - c HDD and ODD bezel
- 3 To remove the front Input/Output (I/O) bezel, pry the edges of the panel [1].

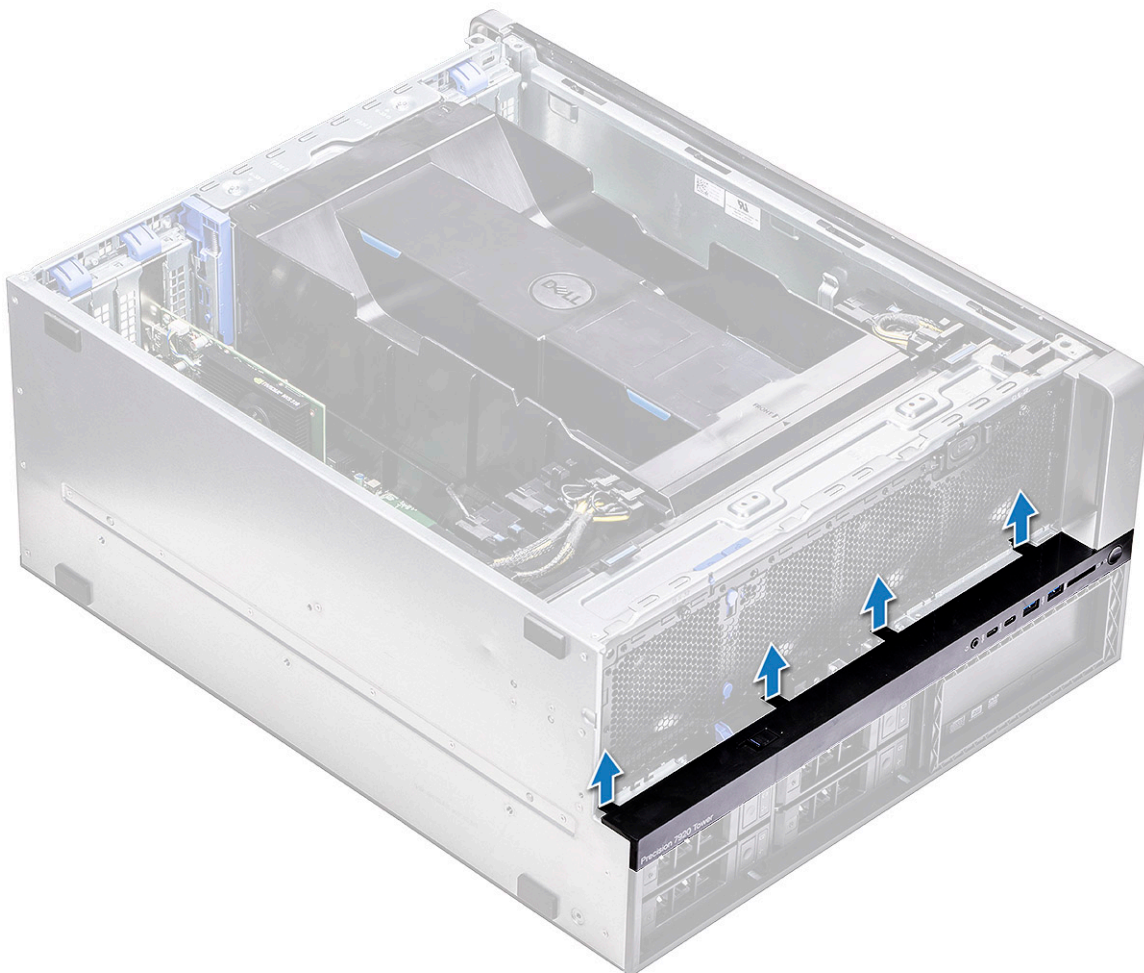

- 4 Slightly slide the panel, and lift it away from the chassis.



Installing the front input and output bezel

- 1 Align and press the bezel toward the front chassis on the system.
- 2 Install the:
 - a HDD and ODD bezel
 - b front bezel
 - c side cover
- 3 Follow the procedure in [After working inside your computer](#)

Front input and output panel

Removing the front input and output panel

- 1 Follow the procedure in [Before working inside your computer](#).
- 2 Remove the following:
 - a side cover
 - b air shroud
 - c front bezel
 - d PCIe holder



- e front system fan
- f HDD and ODD bezel
- g input and output bezel

- 3 To remove the front Input/Output (I/O) panel:
- a Disconnect the following cables from the connectors on the I/O panel.
 - Front panel cable [1]
 - Front USB 3.1 cable [2]
 - Front USB 3.1 cable [3]
 - Front panel audio cable [4]

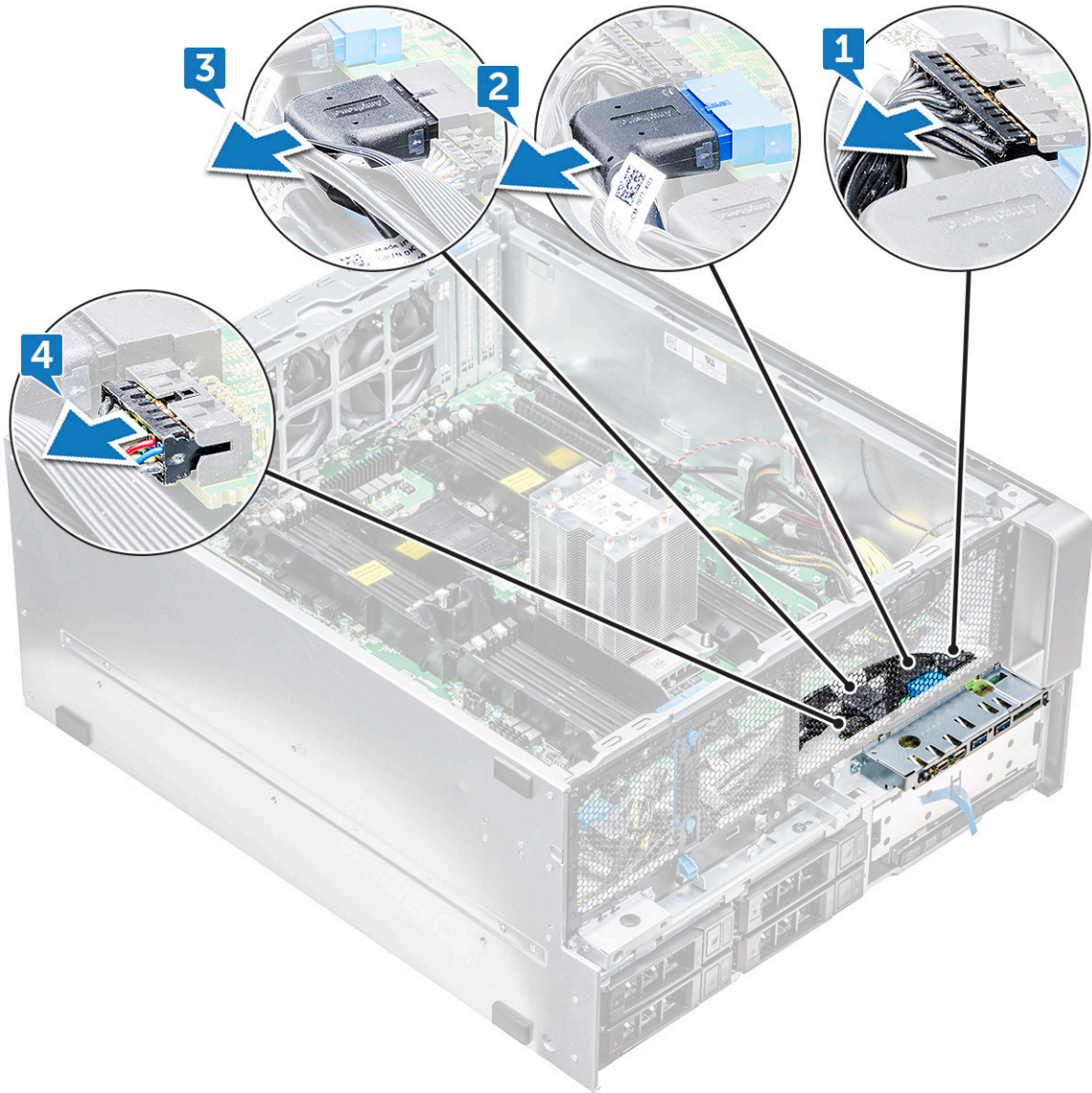

- b Remove the single screw that secures the I/O panel to the chassis.

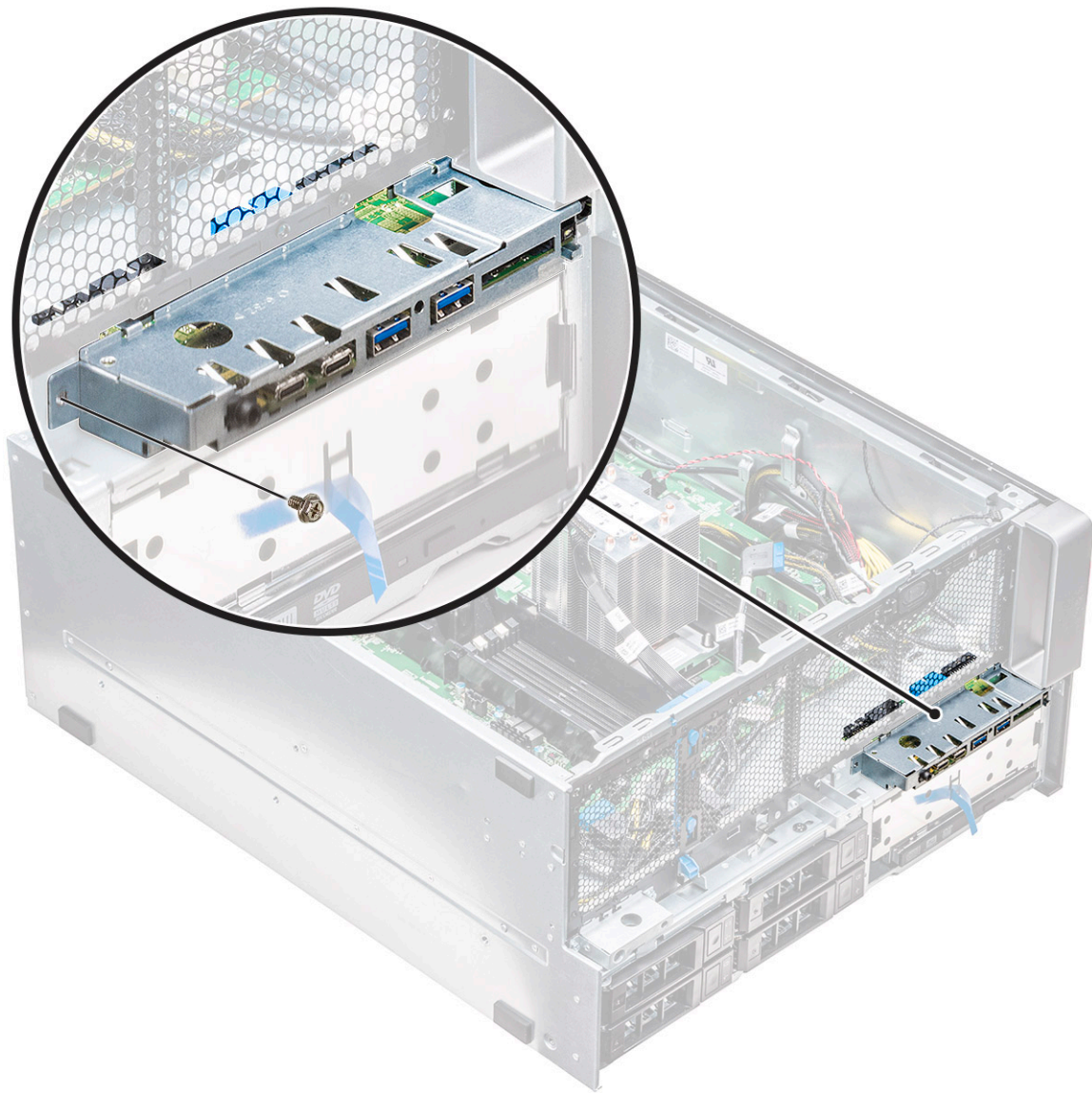

- 4 Slide the I/O panel toward the left of the system to release it, and then remove the I/O panel out of the system.

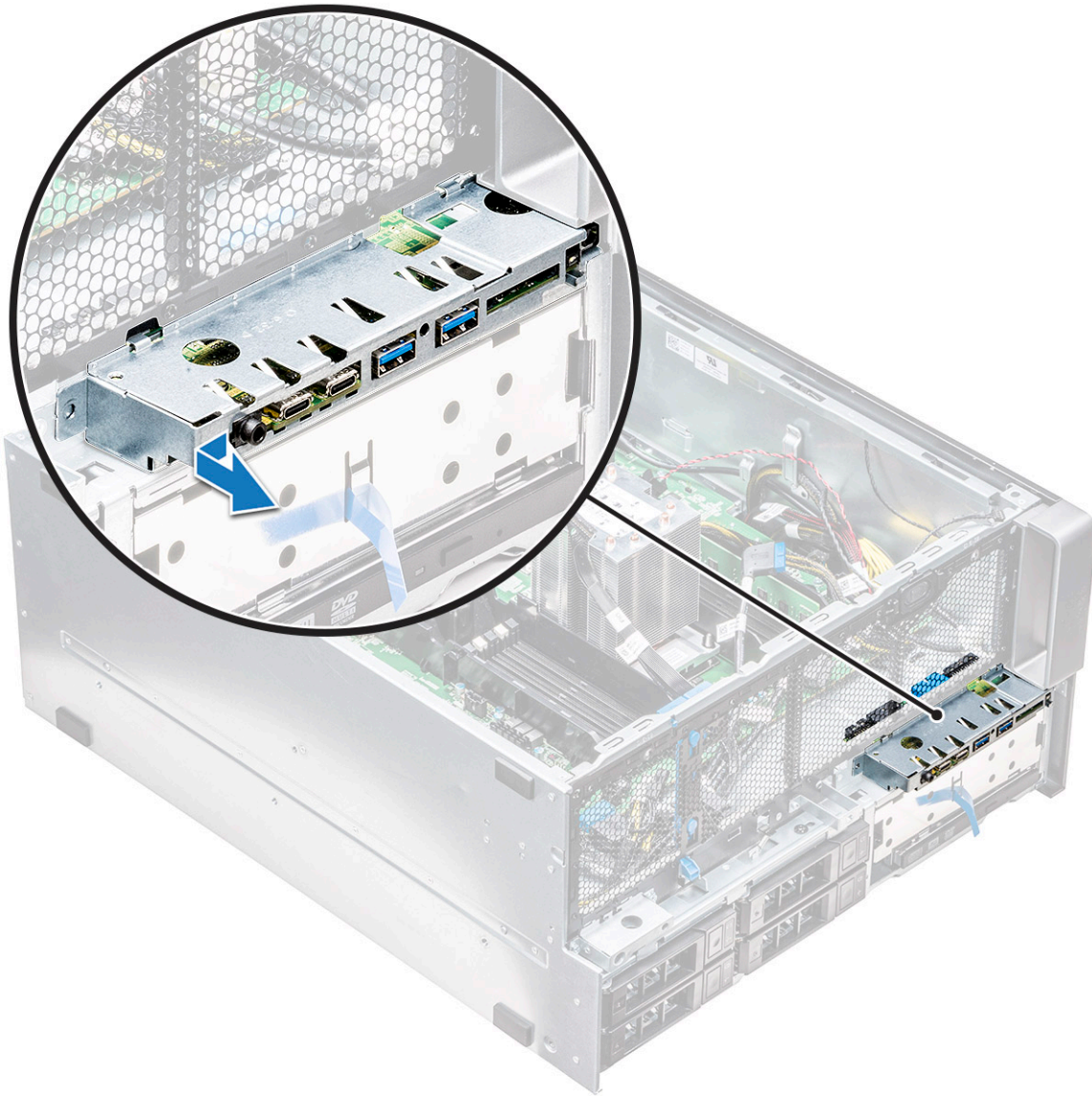

Installing the front input and output panel

- 1 Insert the I/O panel into the slot on the front of the chassis.
- 2 Slide the I/O panel toward the right of the system to secure it to the chassis.
- 3 Replace the screw to secure the I/O panel to the chassis.
- 4 Connect the following cables to the connectors on the I/O panel:
 - Front panel cable
 - Front USB 3.1 cable
 - Front USB 3.1 cable
 - Front panel audio cable

NOTE: The color of the cable matches the color of the connector.

- 5 Install the following:
 - a input and output bezel
 - b HDD and ODD bezel
 - c front system fan

- d PCIe holder
 - e front bezel
 - f air shroud
 - g side cover
- 6 Follow the procedure in [After working inside your computer](#)

Removing the input and output panel bracket

- 1 Follow the procedure in [Before working inside your computer](#).
- 2 Remove the following:
 - a side cover
 - b air shroud
 - c front bezel
 - d PCIe holder
 - e front system fan
 - f HDD and ODD bezel
 - g input and output bezel
 - h input and output panel
- 3 To remove the Input/Output (I/O) panel bracket:
 - a Remove the two screws that secure the I/O panel to the bracket.

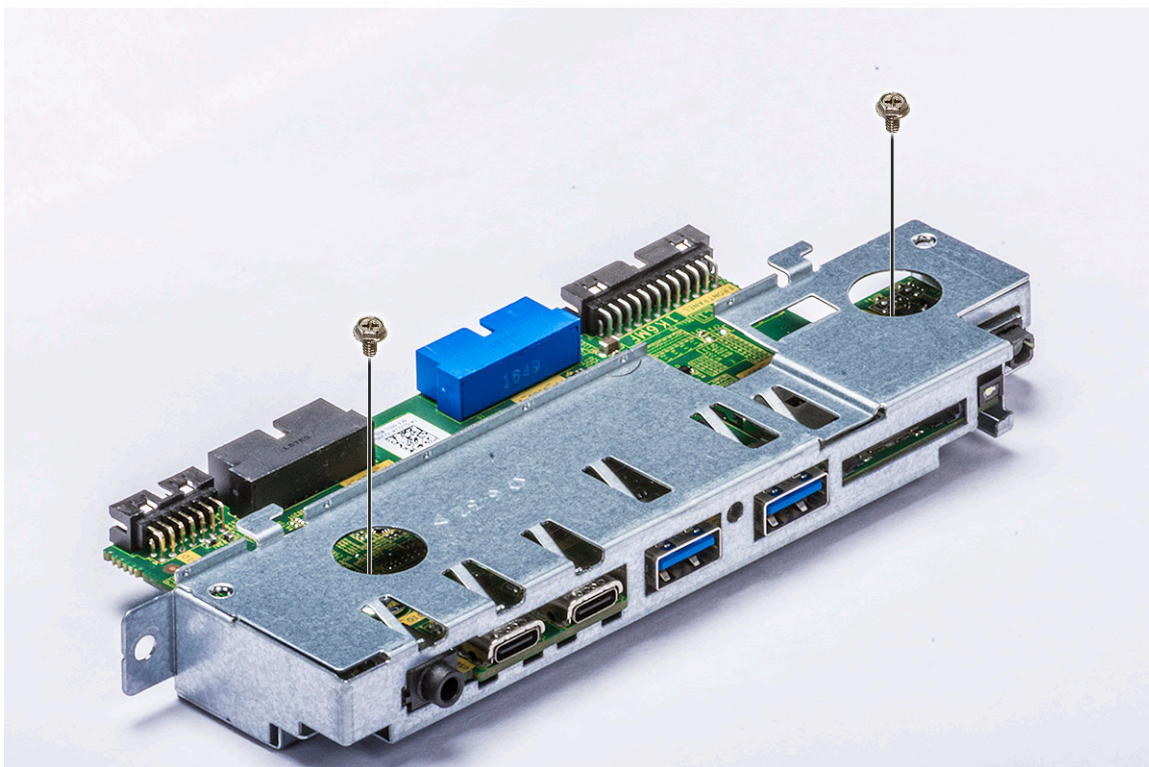

- b Release and remove the I/O panel out of the bracket.

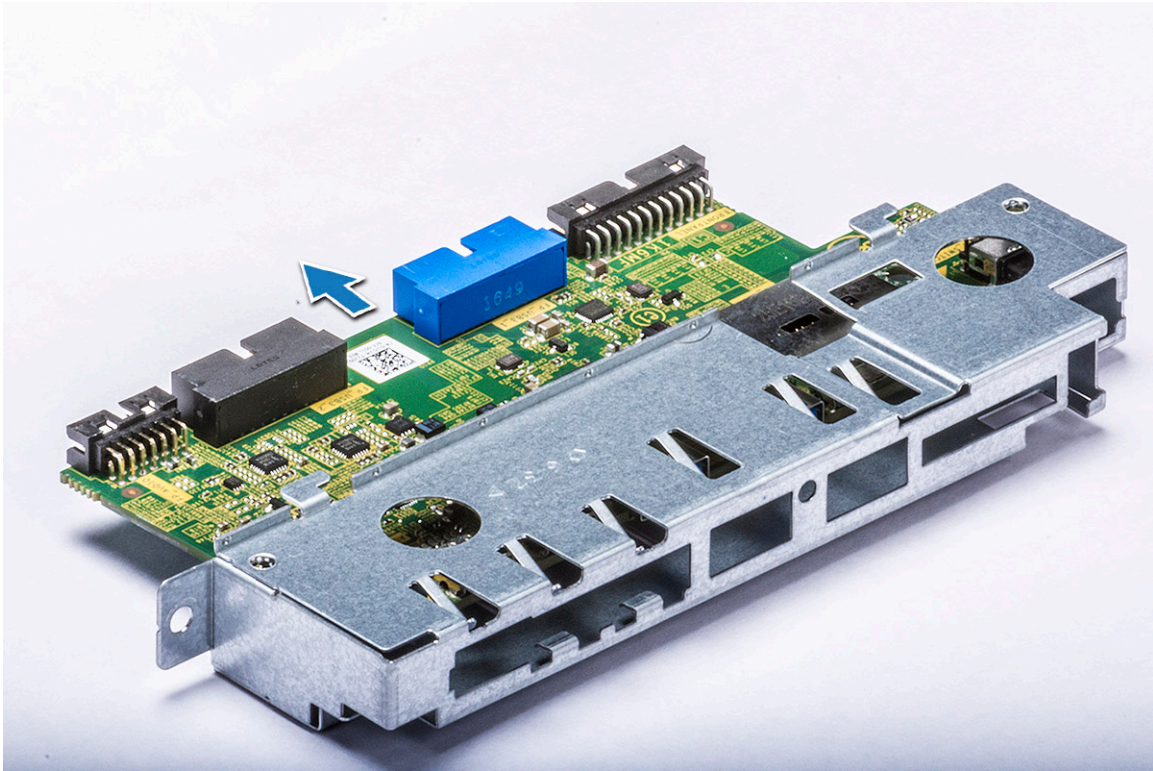

Installing the input and output panel bracket

- 1 Insert the Input/Output (I/O) module into the metal bracket.
- 2 Replace the two screws to secure the I/O panel to the I/O bracket.
- 3 Install the:
 - a [input and output panel](#)
 - b [input and output bezel](#)
 - c [HDD and ODD bezel](#)
 - d [front system fan](#)
 - e [PCIe holder](#)
 - f [front bezel](#)
 - g [air shroud](#)
 - h [side cover](#)
- 4 Follow the procedure in [After working inside your computer](#)

Rear system fan

Removing the rear system fan

- 1 Follow the procedure in [Before working inside your computer](#).
- 2 Remove the following:
 - a [side cover](#)
 - b [air shroud](#)
- 3 To remove the rear system fan assembly:
 - a Remove the two screws [1], and press the tab [2] to rotate the rear system fan into the chassis and remove it from holder.

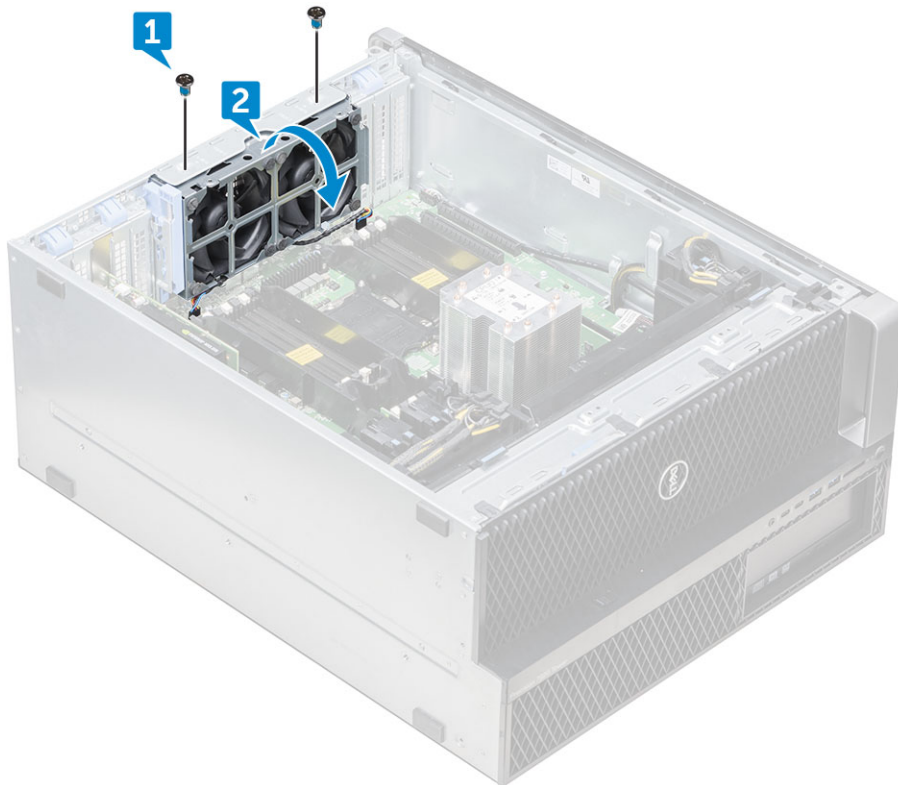

b Disconnect the system fan cables from the system board [1, 2].

CAUTION: Do not pull the connector by the cable wires. Instead, disconnect the cable by pulling on the connector end. Pulling on the cable wires may loosen them from the connector.

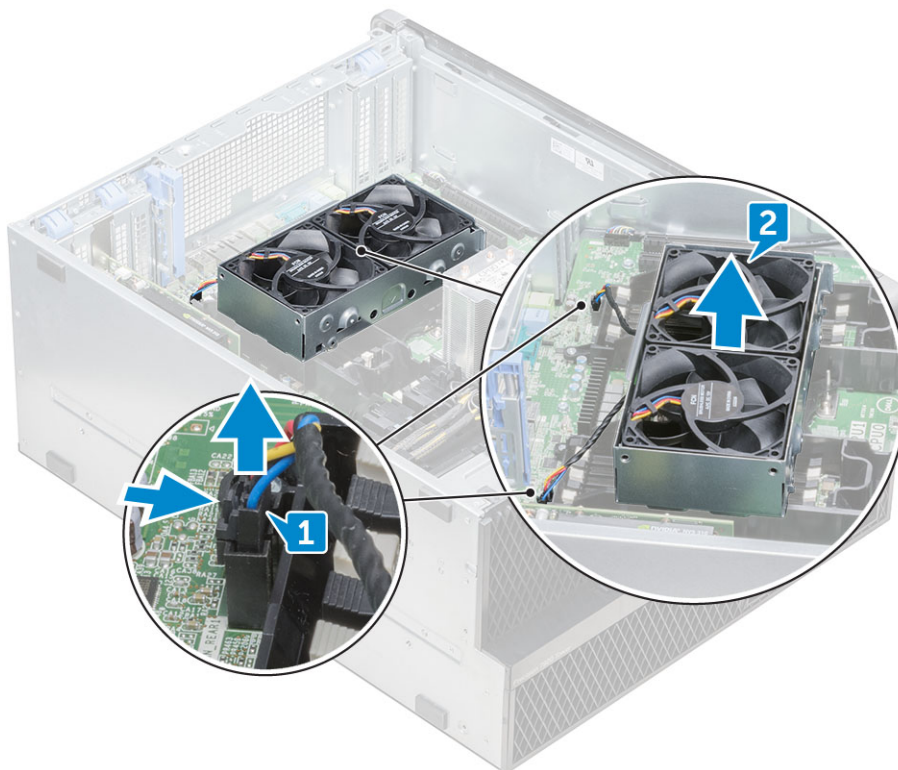

4 Lift the system fan assembly from the system.



Installing the rear system fan

- 1 Hold the rear system fan by the sides with the cable end facing the bottom of the chassis.
- 2 Connect the two system fan cables to the system board.
- 3 Replace the two screws to secure the fan with the chassis.
- 4 Install the:
 - a [air shroud](#)
 - b [side cover](#)
- 5 Follow the procedure in [After working inside your computer](#).

Right side cover

Removing the right side cover

- 1 Follow the procedure in [Before working inside your computer](#).
- 2 Place the system chassis on the side with the right side cover facing upward.
- 3 Remove the two screws [1], that secure the right side cover to the chassis.
- 4 Slide the side cover back with the handle, and then lift it away from the system [2].



Installing the right side cover

- 1 Slide the cover forward and ensure that the hooks on the cover snap into the notches on the system.
- 2 Replace the two screws that secure the right side of the cover to the chassis.
- 3 Follow the procedure in [After working inside your computer](#).

Slim Optical Disk Drive

Removing the slim ODD and ODD latch

- 1 Follow the procedure in [Before working inside the computer](#).
- 2 Remove the [right side cover](#)
- 3 To remove the ODD:
 - a Disconnect the data cable and power cable [1] from the optical drive connector.
 - b Slide the blue latch towards the left of the chassis, and push the drive forward [2].

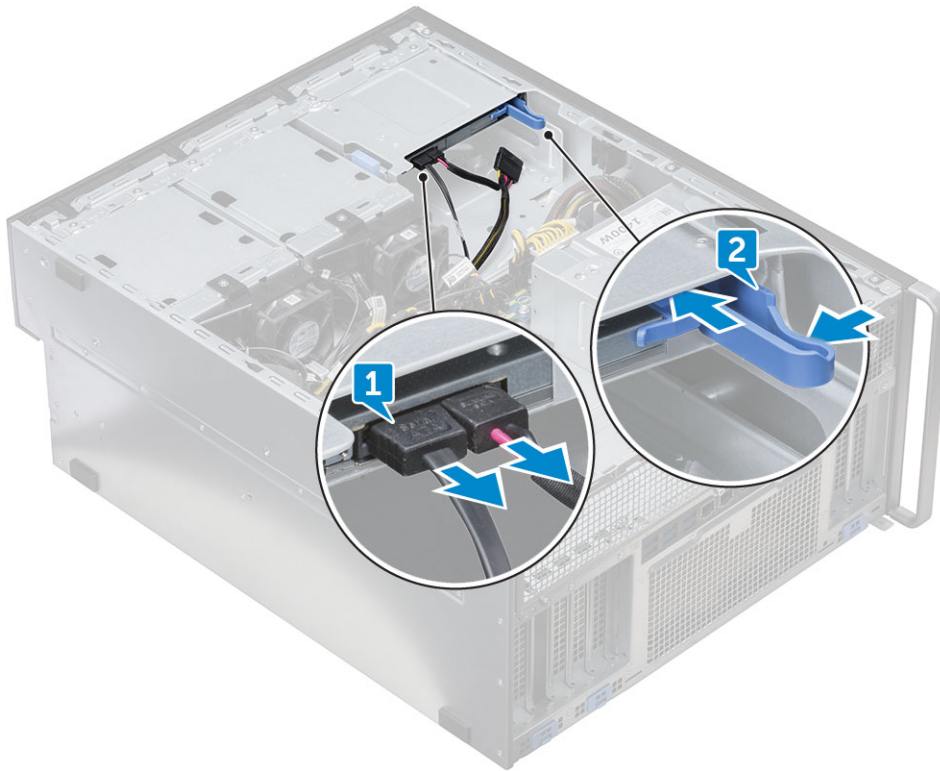

- 4 Remove the ODD out of the drive bay.

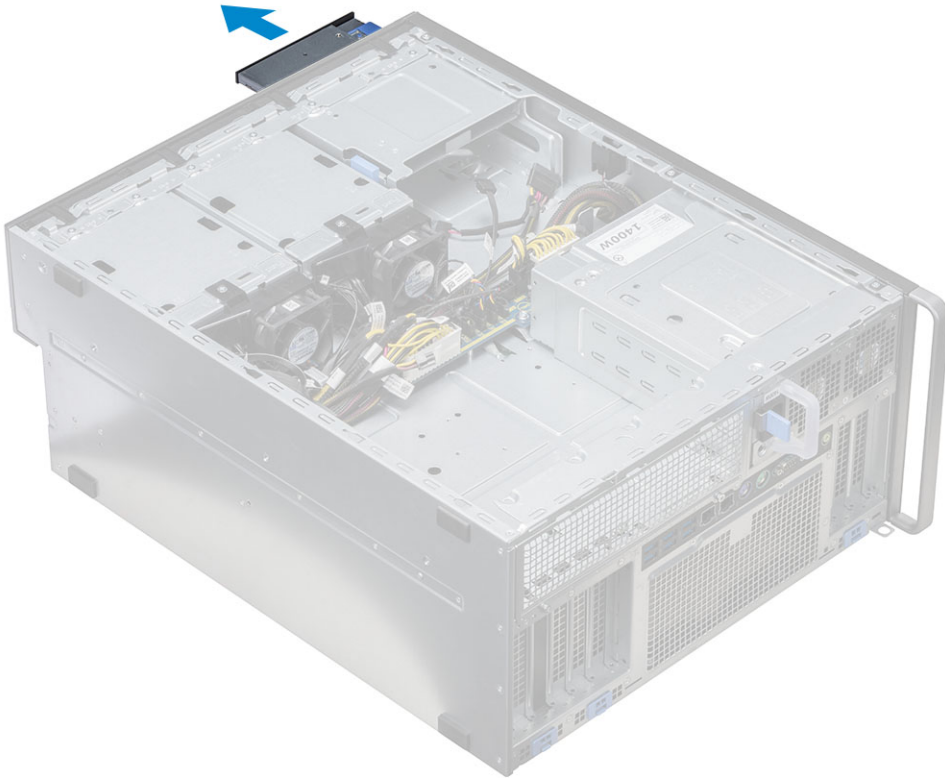

- 5 To remove the ODD bracket from the ODD drive:
- a Push the optical drive latch inwards so that the latch disconnects from the optical drive.



- b Remove the latch from the optical drive.



Installing the slim ODD and ODD latch

- 1 Place the ODD latch into its position on the ODD drive and lock it.
- 2 Slide the optical drive into the drive bay from the front of the system until it fits in to place.
- 3 Connect the data cable and power cable to the connectors on the optical drive.
- 4 Install the [right side cover](#)
- 5 Follow the procedure in [After working inside your computer](#)

Power distribution and fan control board

Removing the power distribution and fan control board

- 1 Follow the procedure in [Before working inside the computer](#).
- 2 Remove the:
 - a [PSU](#)
 - b [right side cover](#)
- 3 To remove the power distribution and fan control board:
 - a Press the tab on both sides of the connector and disconnect the power cable on the control board [1].
 - b Disconnect the fan cables from the connectors on the control board [2].
 - c Disconnect the power, PDB, and power VGA cables from the connectors on the control board [3].

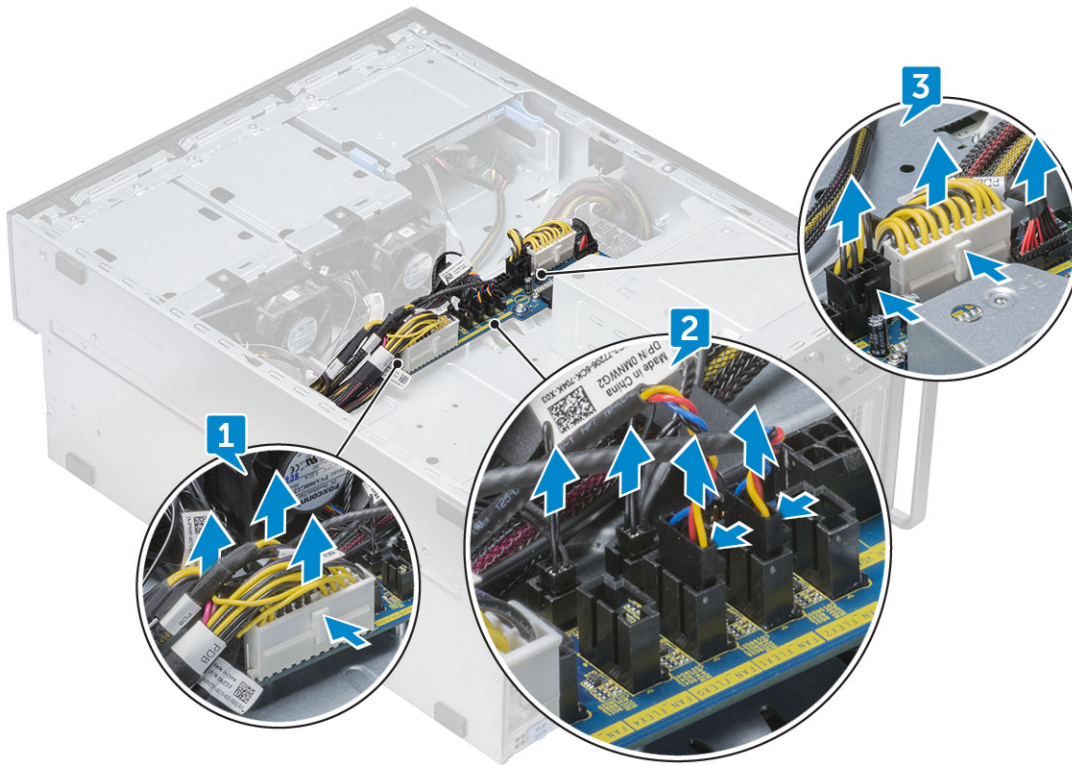

4 Remove the three screws that secure the control board to the chassis [1, 2]. Lift the control board away from the chassis.

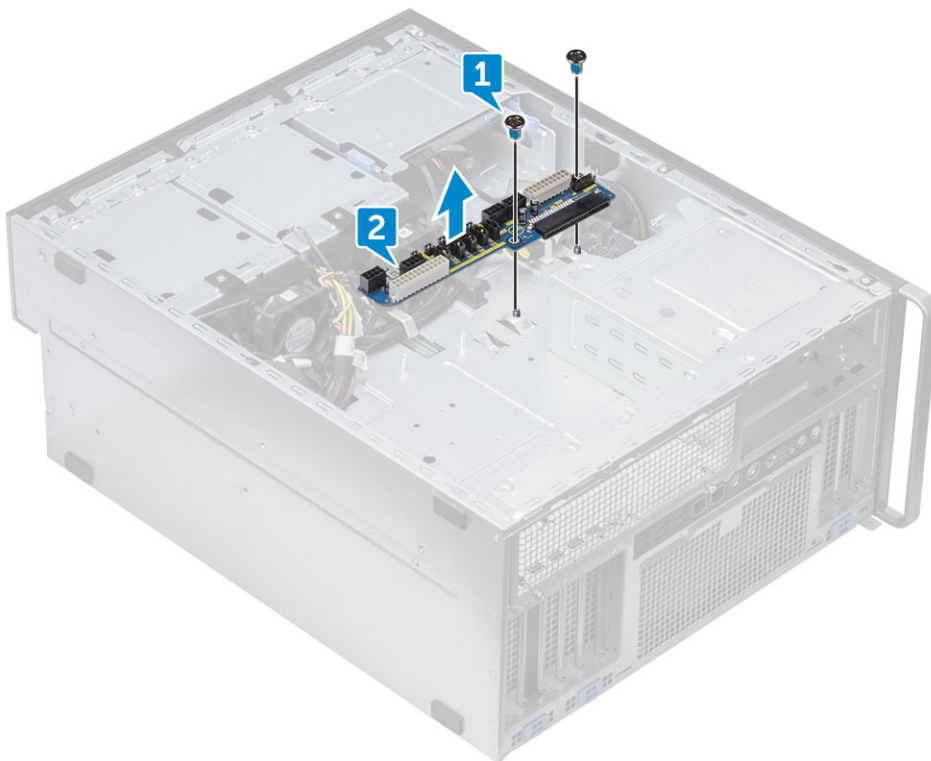

Installing the power distribution and fan control board

- 1 Replace the control board into its slot on the chassis and secure it with the three screws to the chassis.
- 2 Connect the two power cables, fan cables, PDB, power VGA cables, to the connectors on the control board.

- 3 Install the:
 - a right side cover
 - b PSU
- 4 Follow the procedure in [After working inside your computer](#)

Front HDD cable and fan assembly

Removing the front HDD cable and fan assembly

- 1 Follow the procedure in [Before working inside the computer](#).
- 2 Remove the [right side cover](#)
- 3 To remove the front HDD cable and fan assembly:
 - a Remove the four screws securing both the fan brackets to the chassis [1].
 - b Press the tabs of the connector to disconnect the SATA 0 cable from the connector on the system board [2].
 - c Press the tabs to disconnect the power cable and remove it from the plug [3].
 - d Disconnect the fan cables from the connectors on the power distribution and fan control board [4].

CAUTION: Do not pull the connector by the cable wires. Instead, disconnect the cable by pulling on the connector end. Pulling on the cable wires may loosen them from the connector.

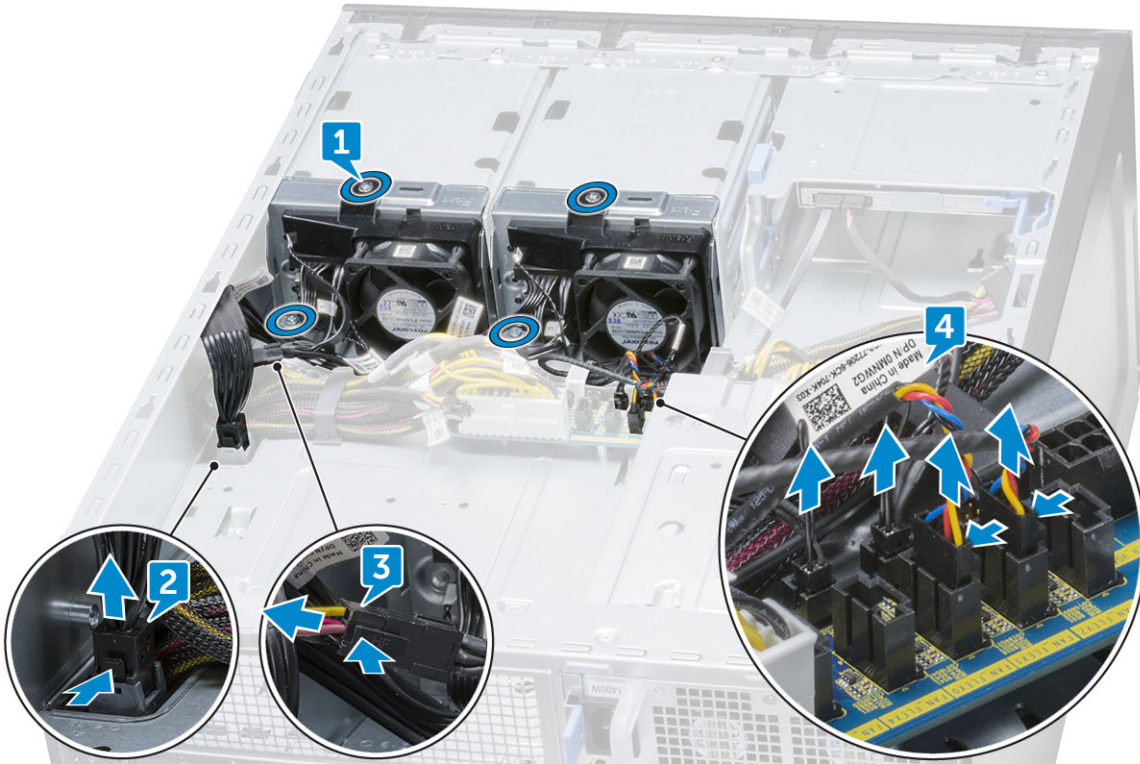

- 4 Remove the HDD fan bracket from the chassis.



Installing the front HDD cable and fan assembly

- 1 Connect the fan cables to the connectors on the power distribution and fan control board.
- 2 Connect the power cable to the connector on the power distribution and fan control board.
- 3 Connect the SATA 0 cable to the connector on the system board.
- 4 Replace the front HDD cable and fan assembly into their slots on the chassis and secure them with screws to the chassis.
- 5 Install the [right side cover](#)
- 6 Follow the procedure in [After working inside your computer](#)

Fan bracket

Removing the fan from the fan bracket

- 1 Follow the procedure in [Before working inside your computer](#).
- 2 Remove the:
 - a [side cover](#)
 - b [system fan](#)
- 3 To remove the fan from the fan bracket:
 - a Slide out the four rubber grommets for each fan from the fan chassis [1].
 - b Lift the fan and remove it from the fan assembly [2].

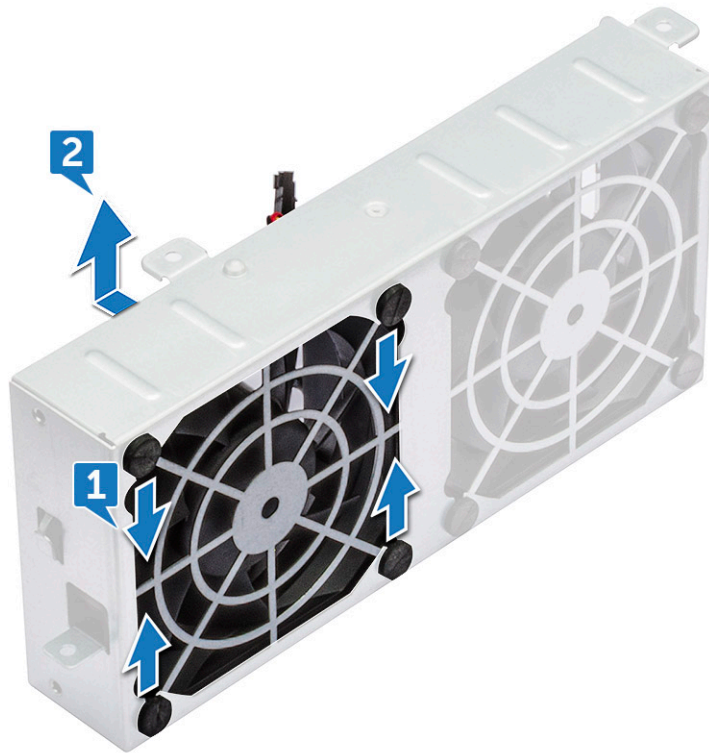

Installing the fan into the fan bracket

- 1 Place the fan into the fan bracket.
- 2 Tighten the grommets that secure the fan to the fan bracket.
- 3 Install the:
 - a [system fan](#)
 - b [side cover](#)
- 4 Follow the procedure in [After working inside your computer](#)

Graphical processing unit(GPU)

Removing the GPU

- 1 Follow the procedure in [Before working inside your computer](#).
- 2 Remove the [side cover](#).
- 3 To remove the GPU:
 - a Disconnect the power cable [1] from the GPU card.
 - NOTE: Not all GPU cards will have power cable, may not apply to all systems.**
 - b Press and rotate the blue clips backward [2], to unlock the filler bracket.

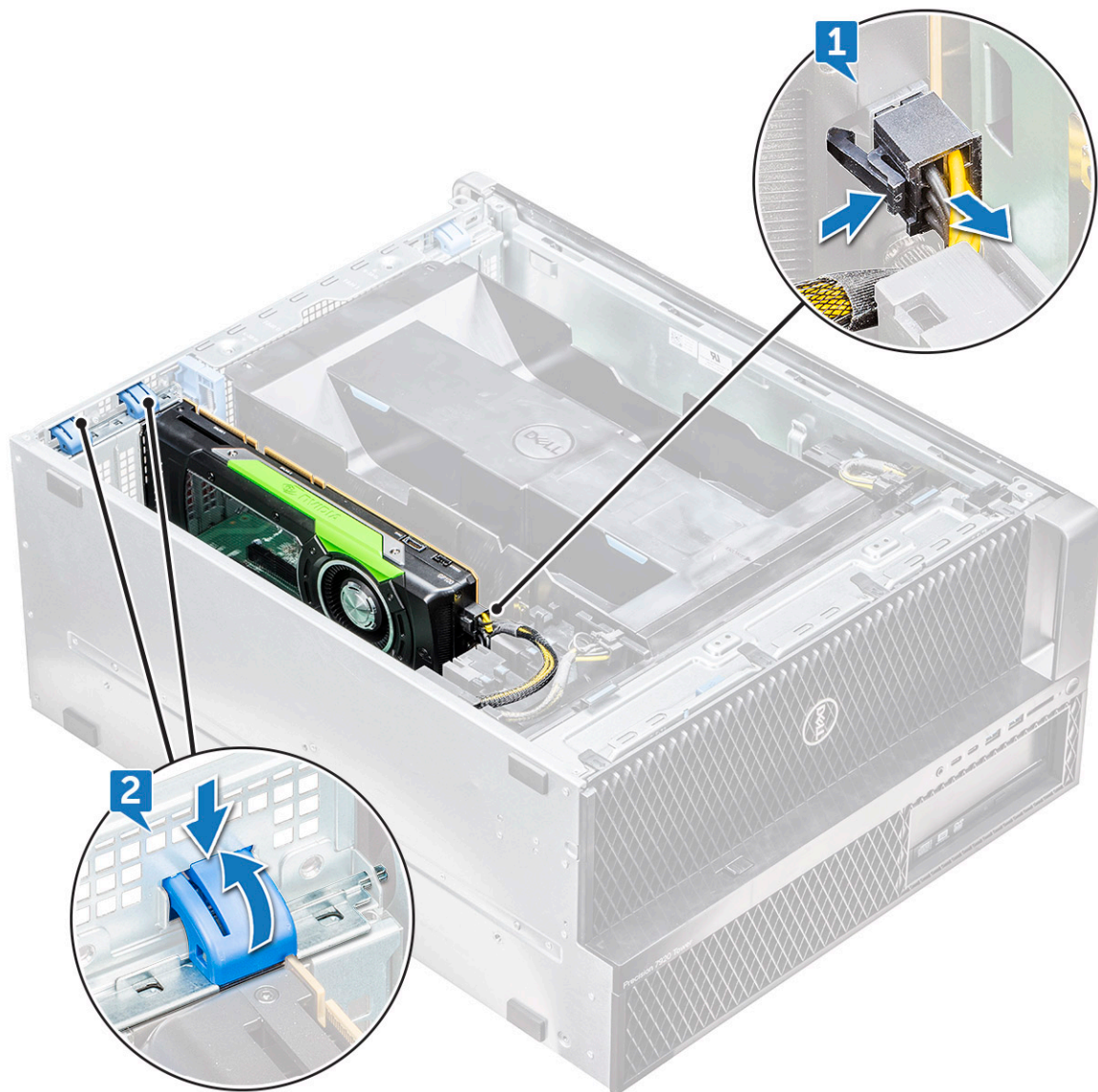

- c Lift the GPU from the PCIe slot on the system board.



Installing the GPU

- 1 Align and place the GPU to the PCIe slot on the system board.
- 2 Press it down so that it is securely seated on the slot.
- 3 Connect the power cable to the GPU.
- 4 Lock both the blue clips forward on the filler bracket to secure the GPU to the system board.
- 5 Install the [side cover](#).
- 6 Follow the procedure in [After working inside your computer](#).

Memory

Removing the memory module

- 1 Follow the procedure in [Before working inside your computer](#).
- 2 Remove the following:
 - a [side cover](#)
 - b [air shroud](#)
- 3 Press the memory module retention tabs on each side of the memory module.



- Lift the memory module out of the memory slot on the system board.

WARNING: Rotating the memory module out of the slot will cause damage to the memory module. Ensure to pull it straight out of the memory module slot.

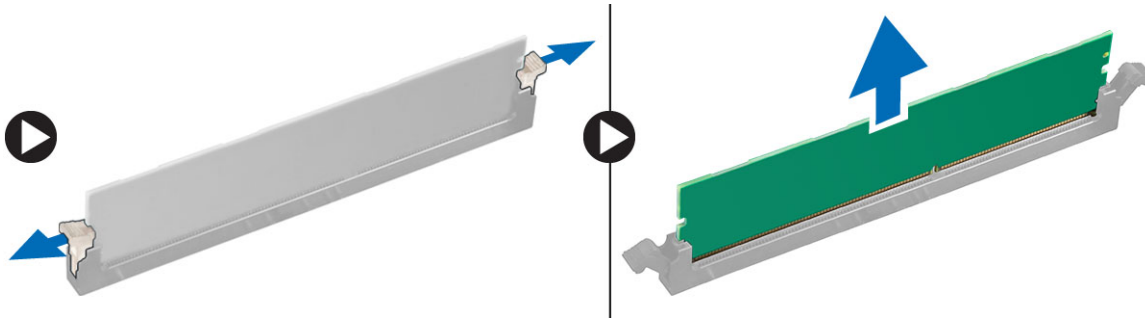

Installing the memory module

- Align the notch on the memory module with the tab on the memory module connector.
- Insert the memory module into the memory module slot.
- Press the memory module firmly until the retention tabs click into place.

NOTE: Do not pull the retention levers up. Always press down firmly on the module until the levers lock into place unassisted.

- Install the:
 - air shroud
 - side cover
- Follow the procedure in [After working inside your computer](#)

Coin cell battery

Removing the coin cell battery

- Follow the procedure in [Before working inside your computer](#).
- Remove the:
 - side cover
 - graphical processing unit(GPU)
 - air shroud
- To remove the coin cell battery:
 - Press the release latch [1] away from the battery to allow the battery to pop-up from the socket [2].

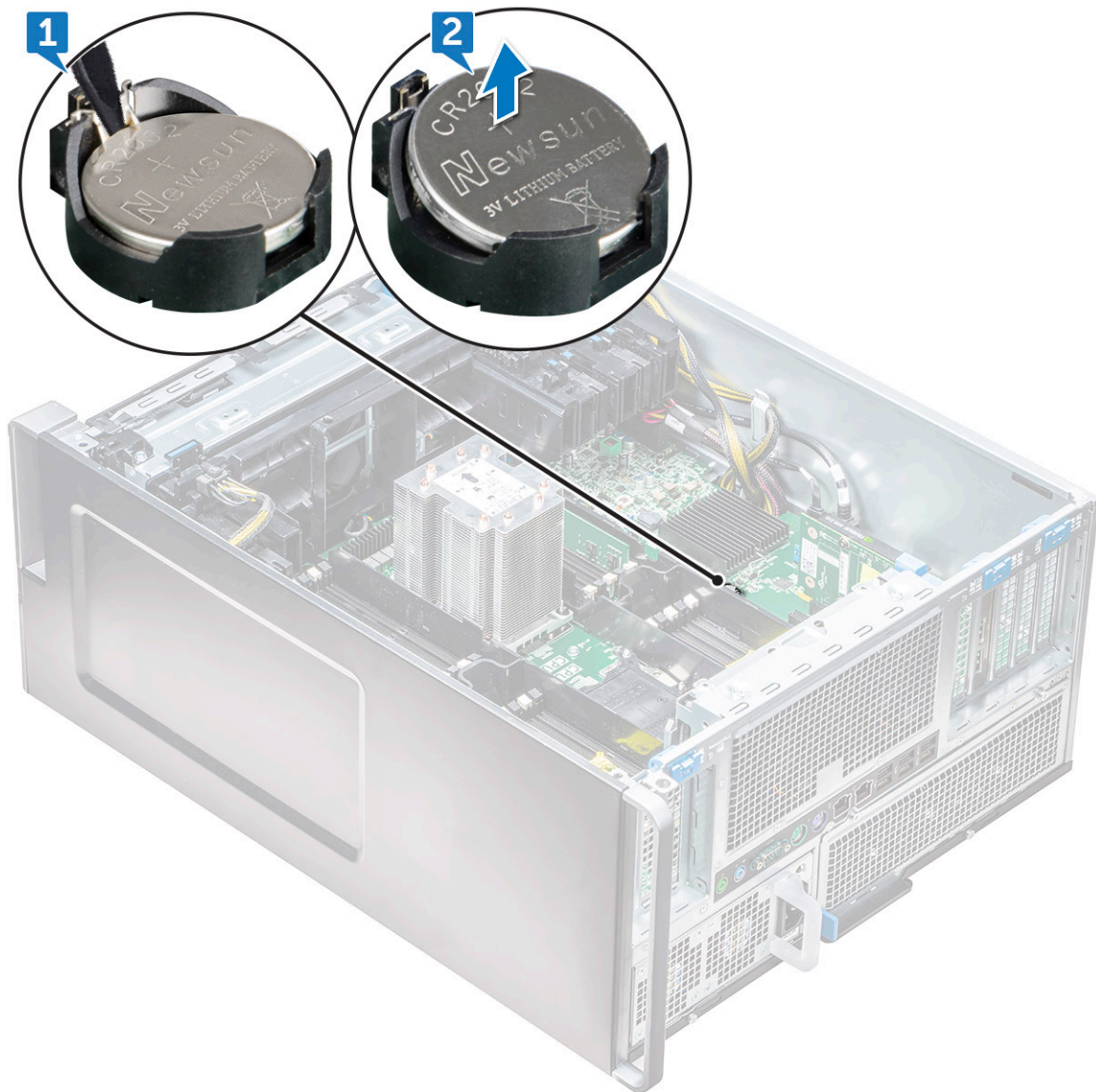

- b Lift the coin-cell battery out of the system board.

Installing the coin cell battery

- 1 Place the coin-cell battery into its slot on the system board.
- 2 Press the coin-cell battery with positive (+) side facing up until the release latch springs back into place and secures it to the system board.
- 3 To install:
 - a [air shroud](#)
 - b [graphical processing unit \(GPU\)](#)
 - c [side cover](#)
- 4 Follow the procedure in [After working inside your computer](#).

Processor heat sink module

Removing the processor heat sink module

1 Follow the procedure in [Before working inside your computer](#).

NOTE: Ensure that you have Torx 30 screwdriver to remove the processor heat sink module (PHM).

2 Remove the:

- a side cover
- b air shroud

3 To remove the heat sink:

- a Remove the four heat sink screws [1], in the diagonal order (4, 3, 2, 1).
- b Lift the heat sink away from the CPU slot on the system board.

CAUTION: CPU will be removed with the heat sink.

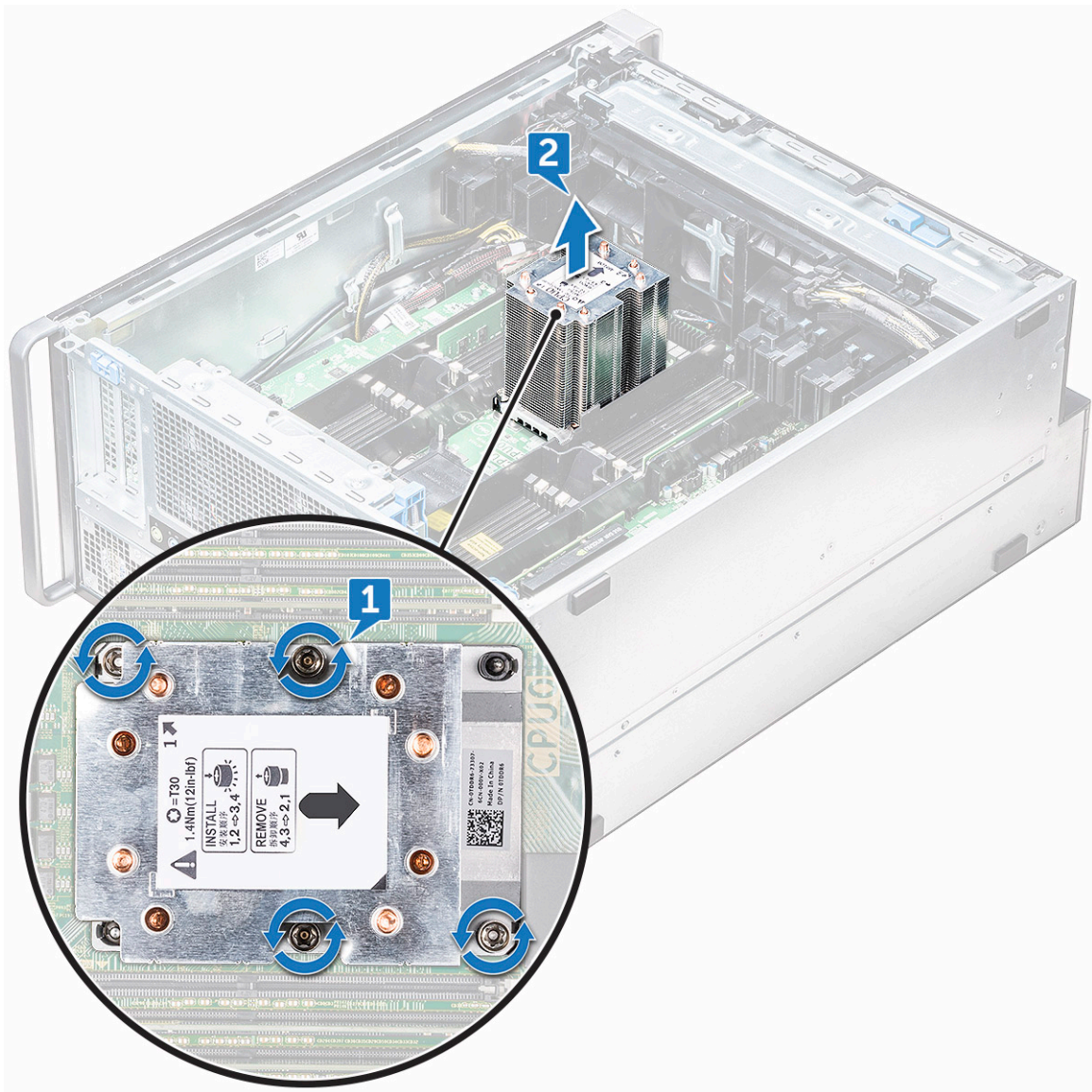

Installing the processor heat sink module

- 1 Place the heat sink on the CPU slot.
- 2 Replace the four screws in the diagonal order (1,2,3,4), to secure the heat sink to the system board.
- 3 Install the:
 - a [air shroud](#)
 - b [side cover](#)
- 4 Follow the procedure in [After working inside your computer](#).

Removing the CPU

- 1 Follow the procedure in [Before working inside your computer](#).
- 2 Remove the:
 - a [side cover](#)
 - b [air shroud](#)
 - c [processor heat sink module](#)
- 3 To remove the central processing unit (CPU):
 - a Hold the processor heat sink module upside down.
 - b Pry the two processor carrier latches [1] from the processor heat sink module.
 - c Press the other two carrier latches [2] of the processor carrier and remove it from the slot in the heat sink.



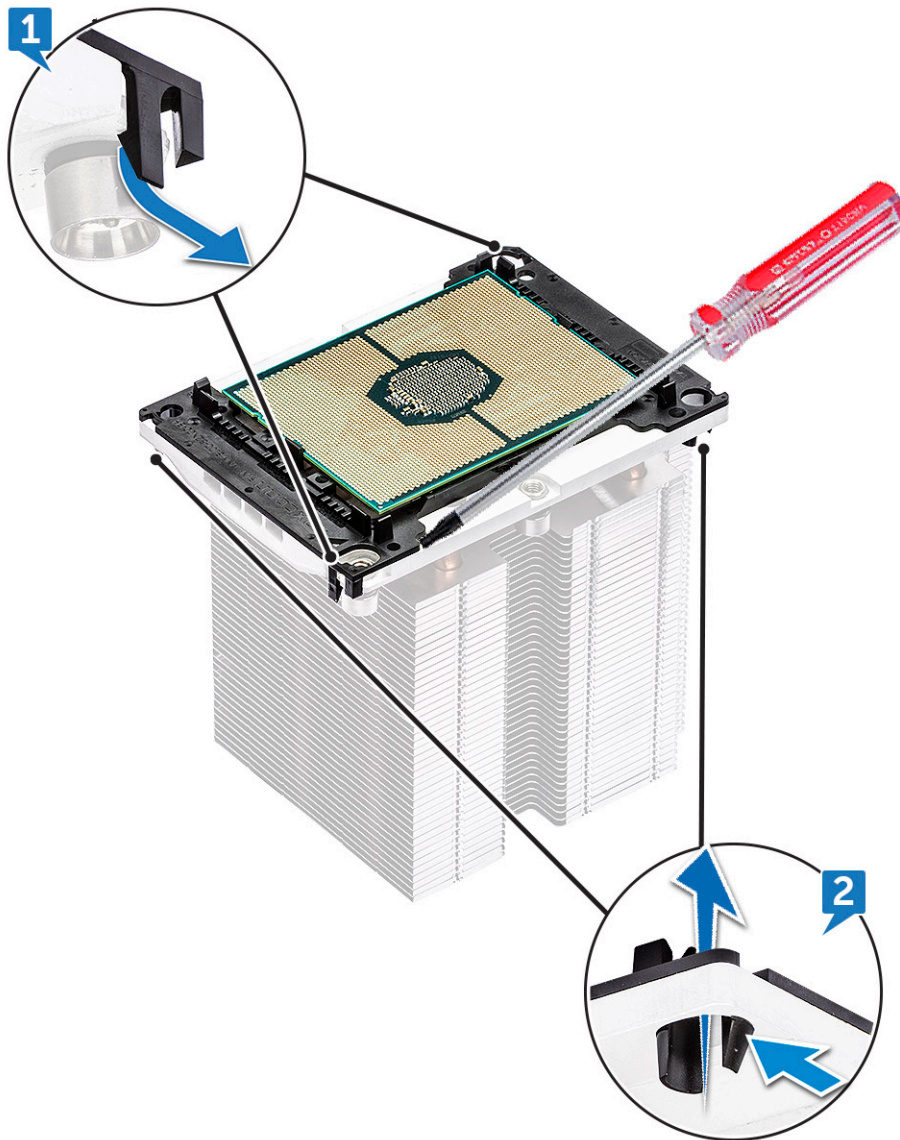

d Use a torx screwdriver to pry the CPU off the processor heat sink module. Place the blade between the clip and the CPU.

NOTE: A flatbed screwdriver or plastic scribe can also be used as well.

e Unlatch the CPU from the two keying latches on the processor carrier and gently lift the CPU.

NOTE: Avoid touching the CPU contacts with your fingers.

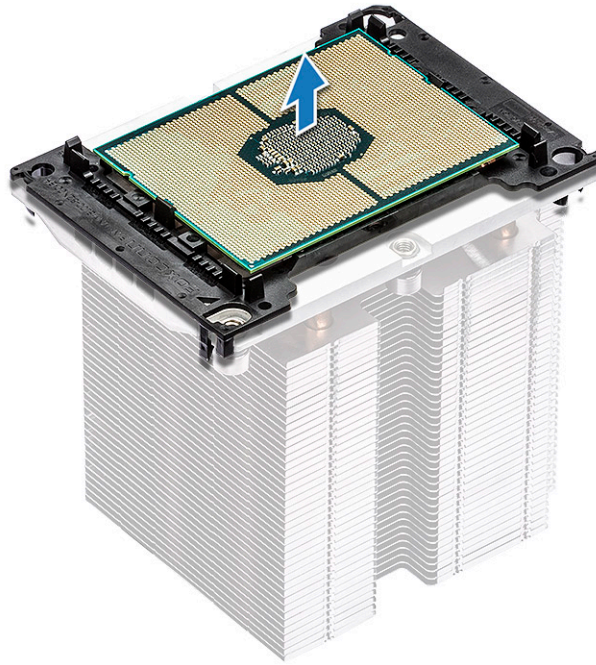

Installing the CPU

- 1 Orient the processor carrier so that the smooth (logo-less) side of the carrier is facing up and the triangle mark on the carrier is on the bottom left hand corner.

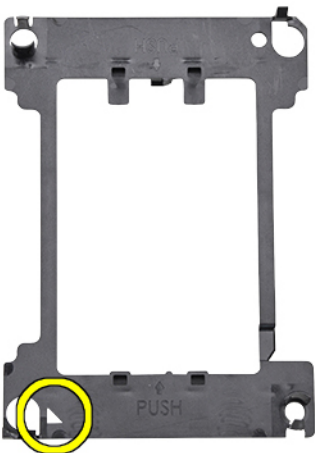

- 2 Align the processor with the carrier so that the triangle mark on the top side of the processor is aligned with the triangle mark on the carrier.

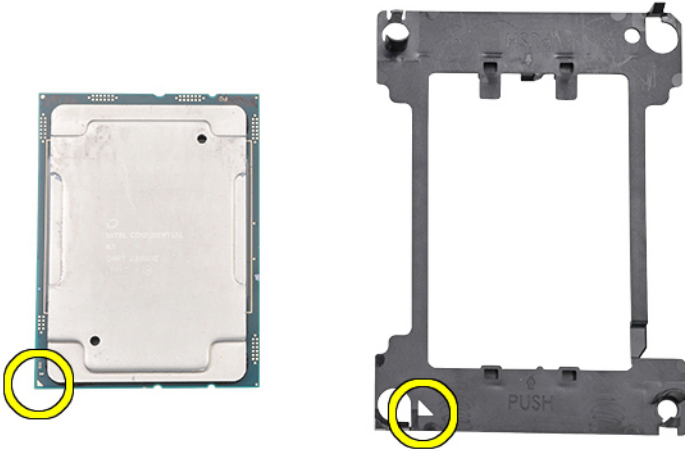

- 3 Flip both the processor and the carrier over so that the pins on the processor and the logo side of the carrier are facing up.

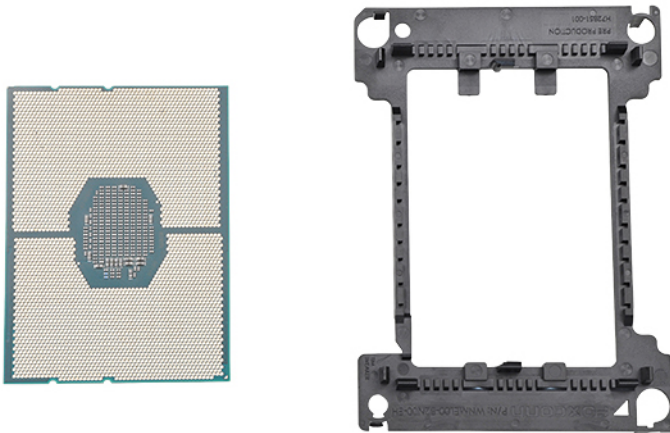

- 4 Carefully insert the processor into the carrier so that it is secured by the hooks on the upper and lower side of the carrier.

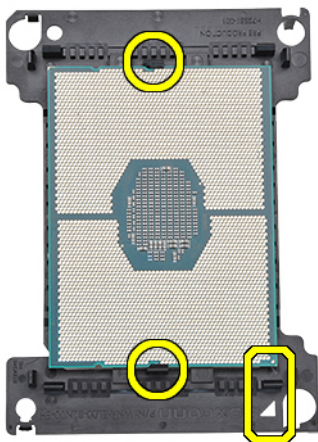

NOTE: After inserting the processor into the carrier, check to see whether the small triangle on the processor aligns with the triangle on the carrier. If they are not aligned repeat the preceding steps.

- 5 Align the processor and carrier assembly with the heat sink so that the triangle marks on the processor and carrier are aligned with the triangle mark on the top side of the heat sink (captive screw #2).

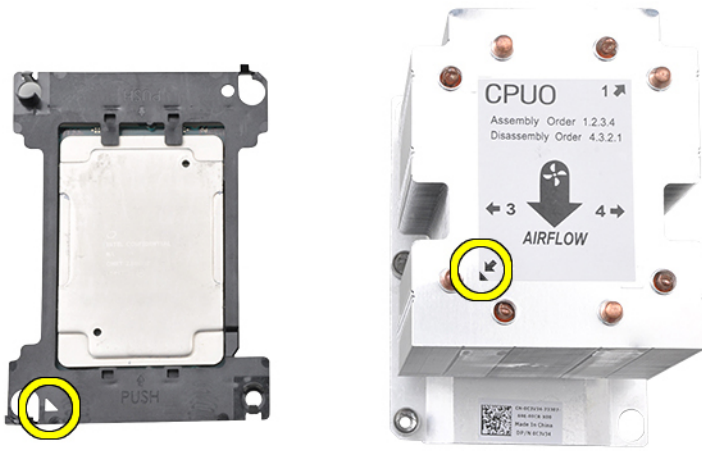

- 6 Insert the processor and carrier assembly into the heat sink so that the hooks on the four corners of the carrier are locked into the openings of heat sink.

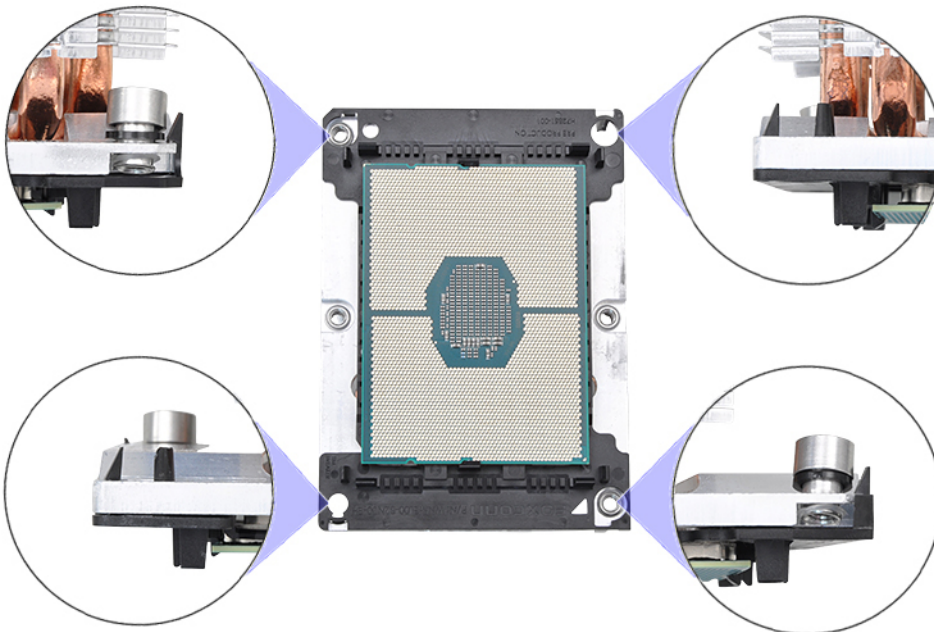

NOTE: After inserting the processor and carrier assembly into the heat sink, double check to see whether the triangle on the carrier is located on the bottom right corner of the heat sink (when the bottom side of the heat sink is facing up).

- 7 Install the processor and heat sink onto the central processing unit (CPU) socket and then secure the four captive screws on the heat sink to the system board in sequential order (1 > 2 > 3 > 4).

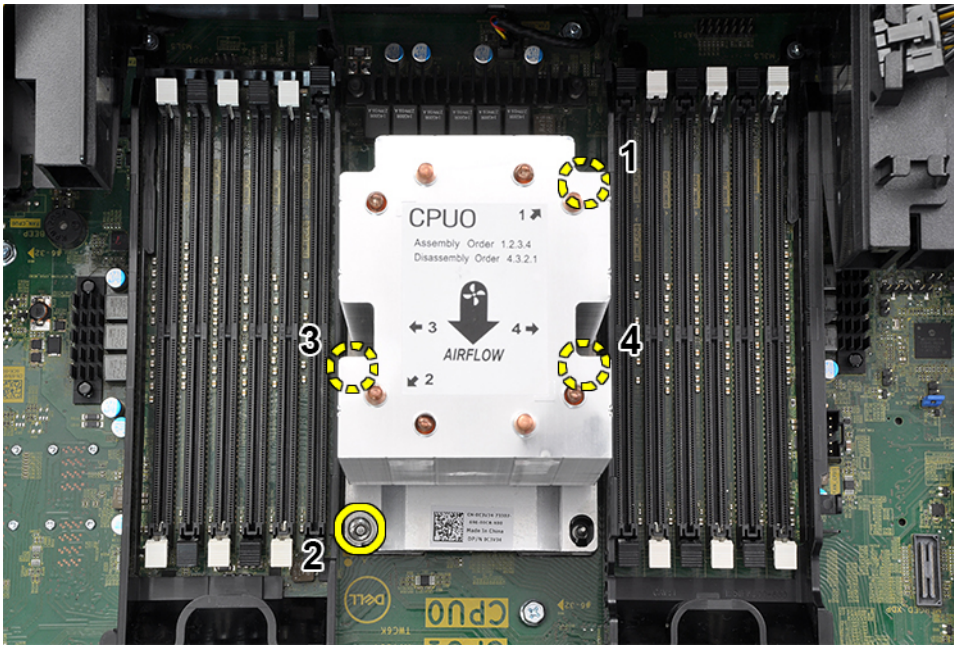

- 8 Install the:
 - a [heat sink](#)
 - b [air shroud](#)
 - c [side cover](#)
- 9 Follow the procedure in [After working inside your computer](#)

System board

Removing system board

- 1 Follow the procedure in [Before working inside your computer](#).
- 2 Remove the:
 - a [side cover](#)
 - b [front bezel](#)
 - c [air shroud](#)
 - d [PCIe card holder](#)
 - e [front system fan](#)
 - f [memory module](#)
 - g [processor heat sink module](#)
 - h [rear system fan](#)
- 3 Disconnect the following cables from the system board:
 - Front panel audio cable [1]
 - Power cable
 - Power control cable
 - Internal chassis speaker cable
 - Intrusion module cable
 - System fan 3 cable [2]

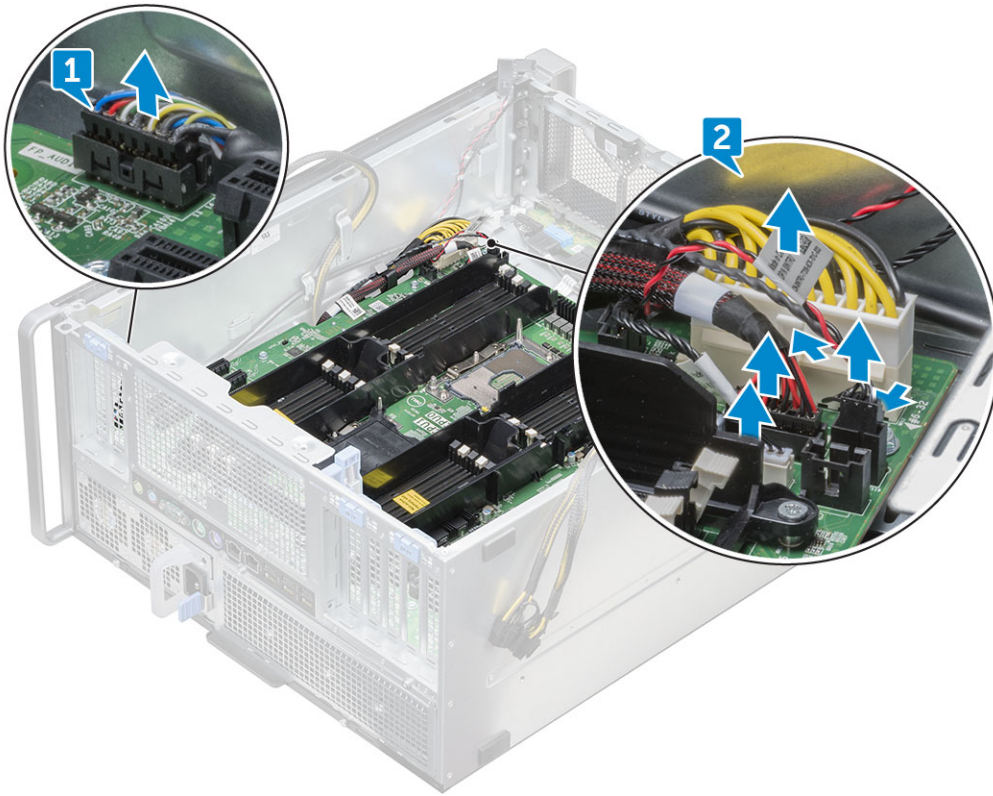

- 4 Disconnect the front panel cables [1], power cable [2], front panel USB 2 cable and DD cable [3]

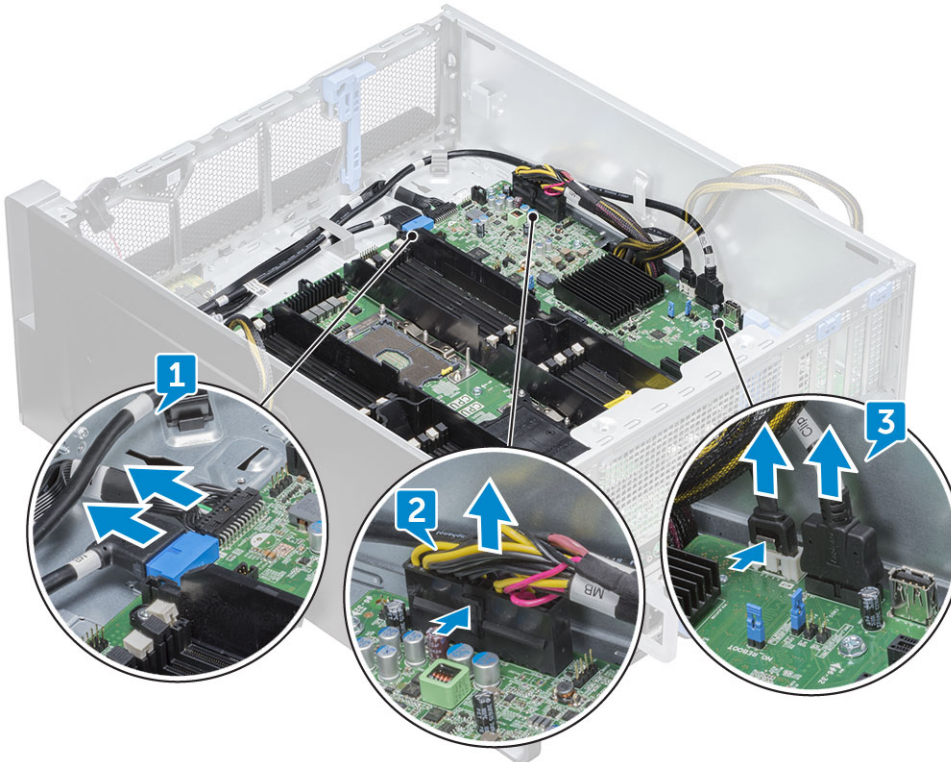

- 5 Remove the [right side cover](#), to disconnect the SATA 0 cable from system board.

NOTE: Depending on the system configuration, additional cables might need to be disconnected.

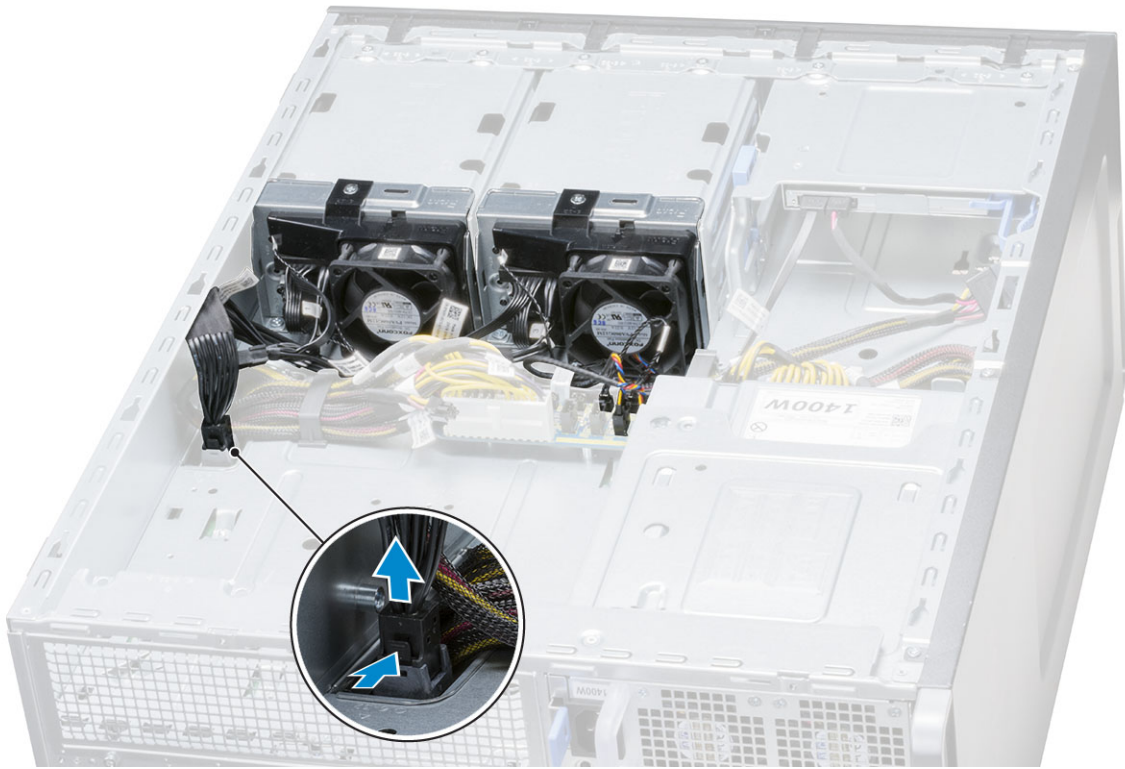

- 6 Remove the twelve screws securing the system board to the chassis.

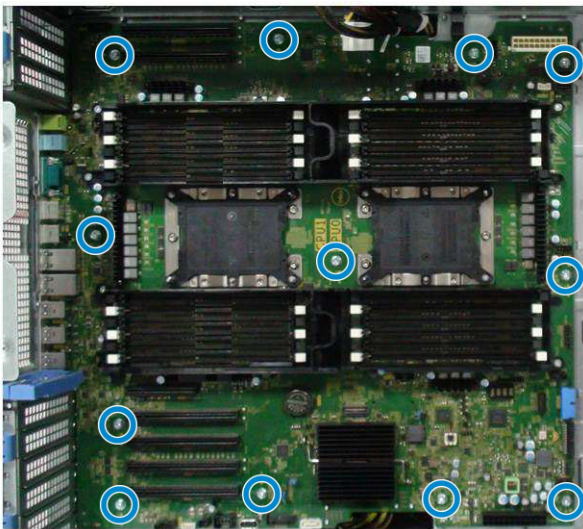

- 7 Lift the system board away from the chassis.

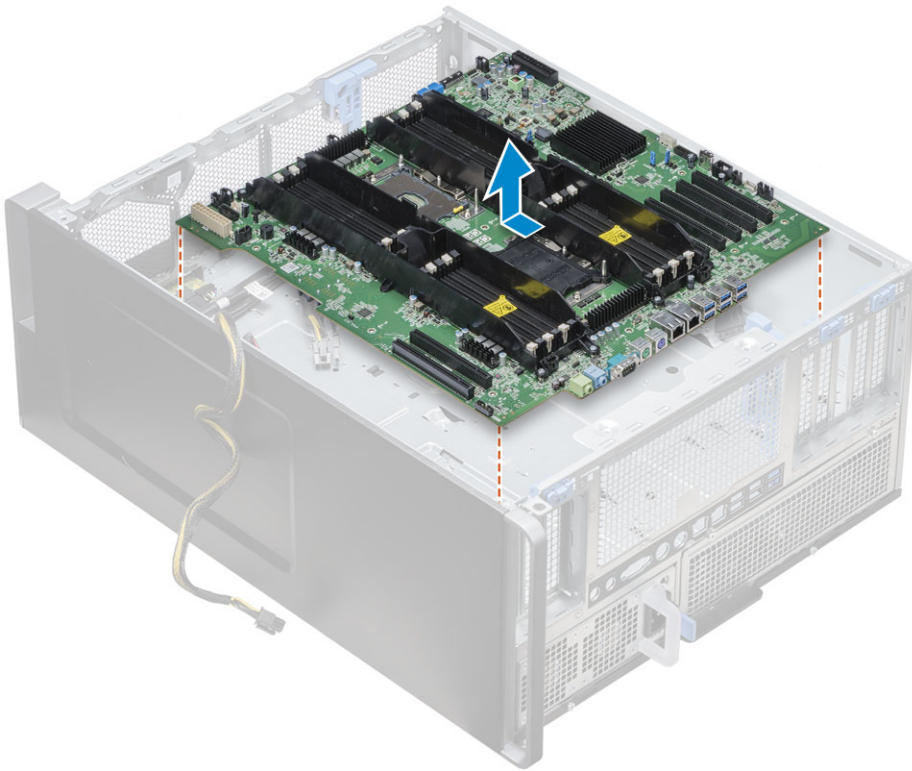

Installing the system board

- 1 Align and place the system board onto the chassis and slide it back to its position.
- 2 Tighten the screws to secure the system board to the chassis.
- 3 Connect all the cables to the connectors on the system board.
- 4 Install the:
 - a rear system fan
 - b processor heat sink module
 - c GPU
 - d memory module
 - e front system fan
 - f PCIe card holder
 - g air shroud
 - h front bezel
 - i side cover
- 5 Flip the system to connect the SATA 0 cable to the connector on the system board.
- 6 Install the right side cover
- 7 Follow the procedure in [After working inside your computer](#)

System board components

Figure 1. Components of the system board

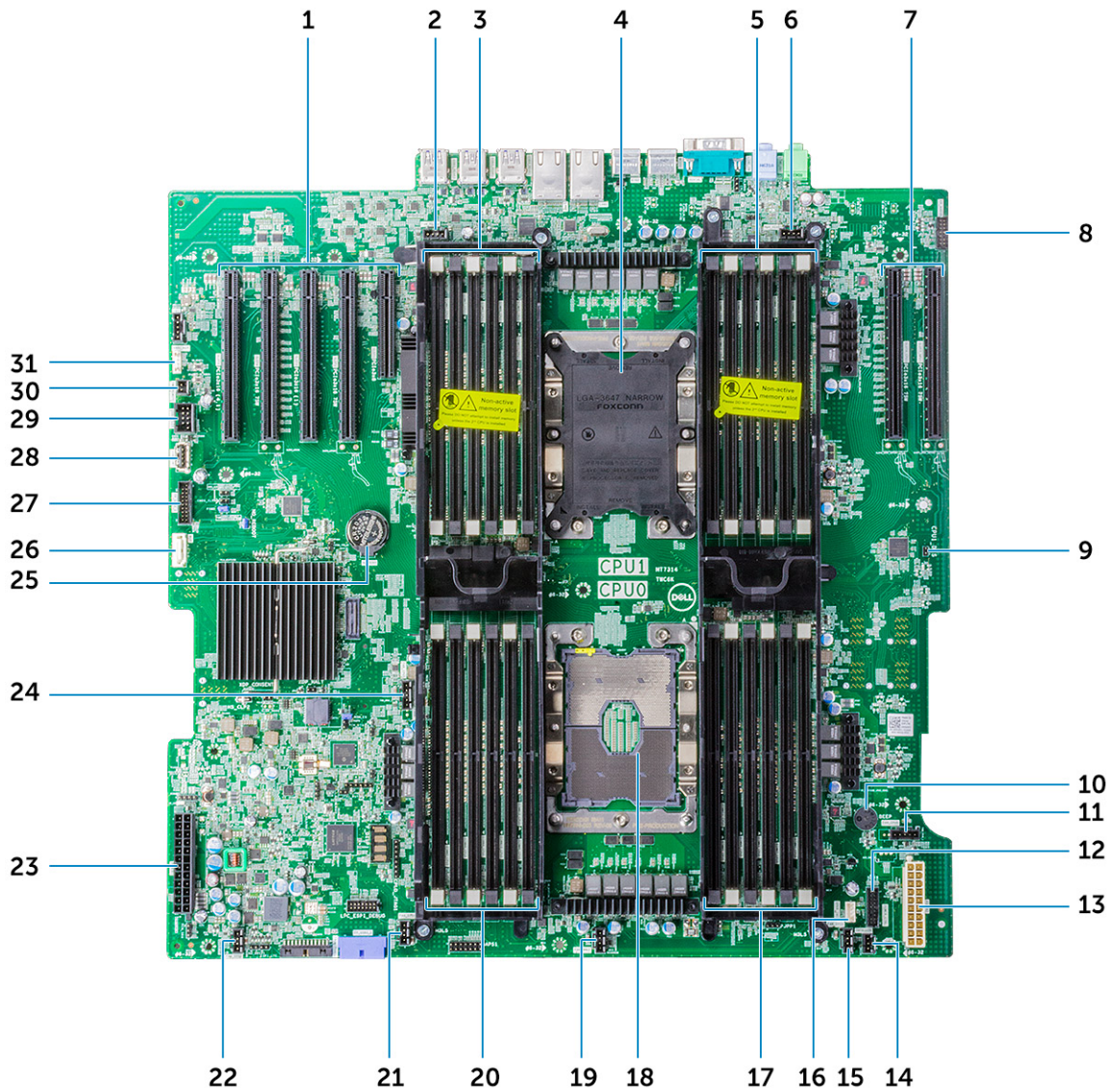

- | | | | |
|----|---------------------------------------|----|----------------------------|
| 1 | PCIe 3*16 (4 slots) and 3*8 (1 slot) | 2 | Rear fan 0 connector |
| 3 | CPU1 memory slots | 4 | CPU1 socket |
| 5 | CPU1 memory slots | 6 | Rear fan 0 connector |
| 7 | CPU1 PCIe 3 x16 Slots (2) | 8 | Front panel audio |
| 9 | CPU1_DIS | 10 | Piezo speaker |
| 11 | CPU fan 0 connector | 12 | Power Control |
| 13 | Power 2 | 14 | Intrusion switch connector |
| 15 | System Fan 3 | 16 | Internal speaker connector |
| 17 | CPU1 memory slots | 18 | CPU 0 socket |
| 19 | System Fan 2 | 20 | CPU1 memory slots |
| 21 | System Fan 1 | 22 | LPC_ESPI_Debug |
| 23 | Power cable 1 | 24 | CPU fan 1 |
| 25 | Coin Cell battery | 26 | ODD cable |
| 27 | Front Panel USB | 28 | USB 2_Int |
| 29 | Flex USB | 30 | Power remote |



Technologies list

This section provides information about the technologies that comes with the Dell Precision 7920 Tower.

The following table lists the basic of technologies that are available on the Dell Precision 7920 Tower systems for Dell internal users only.

Table 2. Technologies list

No.	Category	Technology	Browser Path
1	Chipset	Intel C620 Series Chipset (C621)	
2	Processor	<ul style="list-style-type: none"> • Intel Xeon Platinum 81xx Processor • Intel Xeon Gold 61xx Processor • Intel Xeon Gold 51xx Processor • Intel Xeon Silver 41xx Processor • Intel Xeon Bronze 31xx Processor 	
3	Memory	DDR4	
4	Audio	Integrated Realtek ALC3234 High Definition Audio Codec (2 Channel)	
5	Network	NIC Integrated RJ45	
6	Graphics	Radeon Pro WX <ul style="list-style-type: none"> • 9100 • 7100 • 5100 • 4100 • 3100 • 2100 NVIDIA <ul style="list-style-type: none"> • Quadro GP100 • Quadro P6000 • Quadro P5000 • Quadro P4000 • Quadro P2000 • Quadro P1000 • Quadro P600 • Quadro P400 • NVS 310 • NVS 315 	
7	Storage	SATA SAS Dell UltraSpeed Quad (PCIe M.2 Interposer) Dell UltraSpeed Duo (PCIe M.2 Interposer)	
9	Remote Solutions	1-1 Teradici PCoIP	<ul style="list-style-type: none"> • CLIENT: Dell or other Branded Zero Client (TERA Gen 2) (Dell-Wyse P25) DUAL Monitor Support



No.	Category	Technology	Browser Path
			<ul style="list-style-type: none"> · HOST: PCIe x1 PColP Dual Host Card (TERA Gen 2) · CLIENT: Dell or other Branded Zero Client (TERA Gen 2) (Dell-Wyse P45) QUAD Monitor Support · HOST: PCIe x1 PColP Quad Host Card (TERA Gen 2) · Support Dual Terra Card configurations <p>NOTE: For further information about the Teradici PColP Card host driver installation, see Teradici PColP.</p>

Teradici PColP

This section provides an overview of the host driver installation process.

Installing the Teradici PColP Card Host Dual/Quad

Install the PColP host driver software from dell.com/support.

NOTE: You cannot upgrade the PColP host driver software while a VMware View-brokered PColP session is active between a host workstation or host PC and VMware View client. Doing this will result in losing access to your mouse and keyboard when the driver software is removed.

To upgrade the PColP host driver software in this type of deployment, do one of the following:

- Connect to the host from a zero client.
- Upgrade the software while connecting to the host through another desktop-remoting protocol such as RDP or VNC.

Installing the PColP Host Driver Software on a Host PC:

- 1 Download the PColP host driver software from the Teradici Support site (click Current PColP Product and Releases).
- 2 Log in to the administrative web interface for the host card.
- 3 From the **Configuration > Host Driver Function** menu, enable the Host Driver Function.
- 4 Restart the host PC.
- 5 Install the PColP host software package appropriate for the operating system installed on the host PC. You can start the install process by double-clicking the installer:
 - a 64 bit: PColPHostSoftware_x64-v4.3.0.msi (or later)
- 6 When the Welcome screen appears, click **Next**.
- 7 Accept the terms, and then click **Next**.
- 8 Ensure that the installation location is correct, and click **Next**.
- 9 Click **Install**.

NOTE:

For Windows 7, when the driver is installed, a Windows Security dialog may appear. Click **Install** to continue with the installation. To keep this dialog box from appearing in the future, select **Always trust software from Teradici Corporation**.

- 10 If prompted, restart the operating system; otherwise, skip this step. When restarted, the host driver software installation process continues when the OS boots up. Click **Install** to continue.
- 11 Click **Finish** to complete the installation.

MegaRAID 9440-8i and 9460-16i controller

Small and medium businesses (SMBs) deploying entry-level server platforms and workstations need affordable, reliable storage solutions. The MegaRAID Tri-Mode Storage Adapter is a 12Gb/s SAS/SATA/PCIe (NVMe) controller card that addresses these needs by delivering proven performance and RAID data protection for a range of non-business critical applications. The MegaRAID Tri-Mode storage adapters bring NVMe performance benefits to the storage tier by providing connectivity and data protection for SAS/SATA interfaces. Based on the dual-core SAS3516 or SAS3508 RAID on Chip (ROC) and 72-bit DDR4-2133 SDRAM, these controllers provide bandwidth and IOPS

performance increases and are ideal for high-end servers utilizing internal storage or connecting to large-scale external storage enclosures.

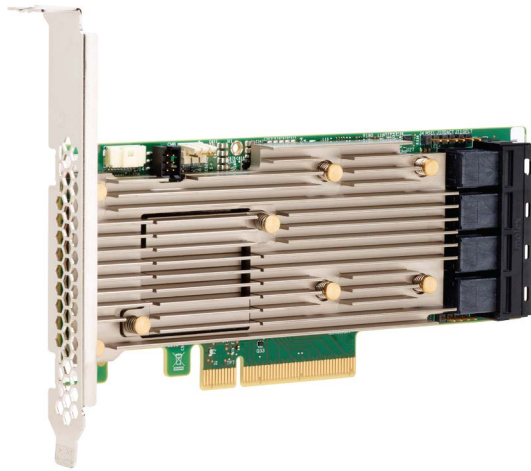

Tri-Mode SerDes Technology enables operation of NVMe, SAS, or SATA storage devices in a single drive bay. All the 3 modes concurrently serving NVMe, SAS, and SATA drives can be operated by a single controller. The controller negotiates between the speeds and protocols to seamlessly work with any of the three types of storage devices. Tri-Mode support provides a non-disruptive way to evolve existing data center infrastructure. By upgrading to a tri-mode controller, users can expand beyond SAS/SATA and use NVMe without major changes to other system configurations. The MegaRAID Tri-Mode storage adapters support both REFCLK and SRIS based NVMe x1, x2, and x4 devices.

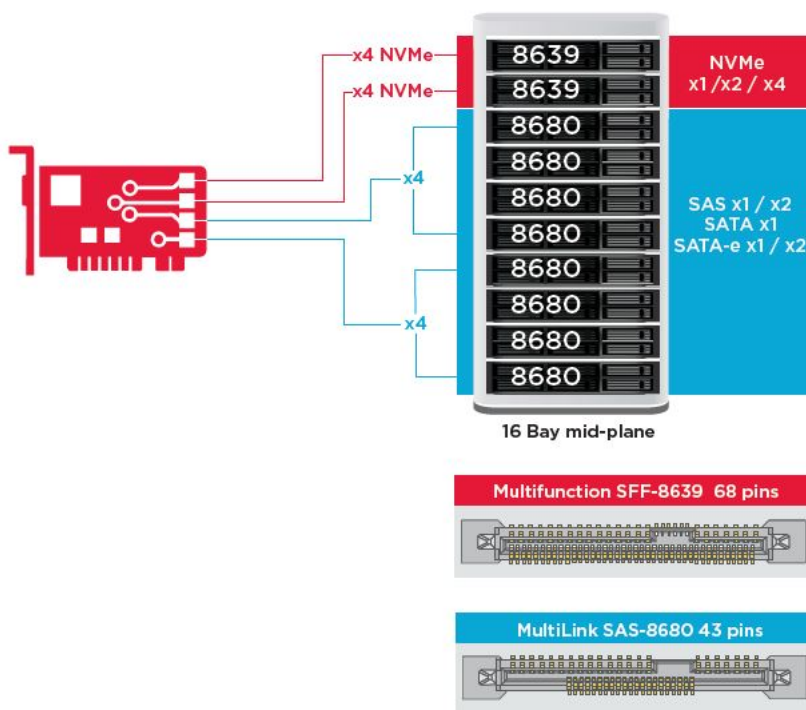

Key Features:

- Tri-Mode SerDes Technology enables the operation of NVMe, SAS or SATA devices in a single drive bay, allowing for endless design flexibility
- Supports 12, 6, and 3 Gb/s SAS and 6, 3 Gb/s SATA data transfer rates
- Up to 8 PCIe links. Each link supporting x4, x2, or x1 link widths, supporting 8.0 GT/s (PCIe Gen3) per lane
- SFF-9402 Compliant, Connector Pin-out



- SFF-8485 Compliant, SGPIO
- Fits into rack-mounted servers with low-profile form factor and side-mounted SAS connectors
- Support critical, high-bandwidth applications with PCIe 3.1 connectivity
- CacheVault flash back-up at power fail. Supports bad block management
- Balance protection and performance for critical applications with RAID levels 0, 1, 5, 6, 10, 50, and 60

Table 3. Features of MegaRAID 9440-8i and 9460-16i controller

	9440-8i	9460-16i
Ports	8 internal	16 internal
Connectors	2 x SFF8643	4 x SFF8643 x4
Storage Interface Support	SATA: Eight x1	SATA: Sixteen x1
	SAS: One x8, Two x4, Four x2, Eight x1	SAS: Two x8, Four x4, Eight x2, Sixteen x1
	NVMe: Two x4, Four x2, Four x1	NVMe: Four x4, Eight x2, Eight x1
Max Devices Per Controller	SAS/SATA: 64	SAS/SATA: 240
	NVMe: 4	NVMe: 24
Cache Memory	N/A	4 GB 2133 MHz DDR4 SDRAM
I/O Processor / SAS Controller	SAS3408	SAS3516
Host Bus Type	PCIe 3.1 x8	PCIe 3.1 x8
Cache Protection	N/A	CacheVault
		CVPM05
Physical Dimensions	6.127" x 2.712" (155.65 mm x 68.90 mm)	6.127" x 2.712" (155.65 mm x 68.90 mm)
Maximum Operating Conditions	Operating:	Operating:
	10°C to 55°C	10°C to 55°C
	20 to 80% non-condensing	20 to 80% non-condensing
	Airflow: 300 LFM	Airflow: 300 LFM
	Storage:	Storage:
	-45°C to 105°C	-45°C to 105°C
	5 to 90% non-condensing	5 to 90% non-condensing
MTBF (Calculated)	>3,000,000 hours at 40C	>3,000,000 hours at 40C
Operating Voltage	+12V +/-8%; 3.3V +/-9%	+12V +/-8%; 3.3V +/-9%
Hardware Warranty	3 years; with advanced replacement option	3 years; with advanced replacement option
MegaRAID Management Suite	LSI Storage Authority (LSA)	LSI Storage Authority (LSA)
	StorCLI (command-line interface), CTRL-R (BIOS configuration utility), HII (UEFI Human Interface Infrastructure)	StorCLI (command-line interface), CTRL-R (BIOS configuration utility), HII (UEFI Human Interface Infrastructure)
Regulatory Certifications	USA (FCC 47 CFR part 15 Subpart B, class B); Canada (ICES -003, Class B); Taiwan (CNS 13438); Japan (VCCI V-3);	USA (FCC 47 CFR part 15 Subpart B, class B); Canada (ICES -003, Class B); Taiwan (CNS 13438); Japan (VCCI V-3);



9440-8i**9460-16i**

Australia/New Zealand (AS/NZS CISPR 22); Korea (RRA no 2013-24 & 25); Europe (EN55022/EN55024);

Australia/New Zealand (AS/NZS CISPR 22); Korea (RRA no 2013-24 & 25); Europe (EN55022/EN55024);

Safety: EN/IEC/UL 60950; RoHS; WEEE

Safety: EN/IEC/UL 60950; RoHS; WEEE

OS Support

Microsoft Windows, VMware vSphere/ESXi, Red Hat Linux, SuSe Linux, Ubuntu Linux, Oracle Linux, CentOS Linux, Debian Linux, Fedora, and FreeBSD. Contact Oracle support for Oracle Solaris driver or software support.

Microsoft Windows, VMware vSphere/ESXi, Red Hat Linux, SuSe Linux, Ubuntu Linux, Oracle Linux, CentOS Linux, Debian Linux, Fedora, and FreeBSD. Contact Oracle support for Oracle Solaris driver or software support.

Expansion card installation guidelines

Depending on your system configuration, the following PCI Express(PCIe)generation 3 expansion cards are supported:

Table 4. Expansion card riser specifications

Expansion card riser	PCIe slots on the riser	Processor connection	Height	Length	Link	Slot width
Riser 1C	Slot 1	Processor 1	Full Height	Full Height	x16	x16
Riser 1C	Slot 2	Processor 1	Full Height	Full Height	x8	x16
Riser 1C	Slot 3	Processor 1	Full Height	Full Height	x8	x16
Riser 2A	Slot 4	Processor 2	Full Height	Full Height	x16	x16
Riser 2A	Slot 5	Processor 2	Full Height	Full Height	x8	x16
Riser 2A	Slot 6	Processor 1	Low Profile	Half Length	x8	x16
Riser 3A	Slot 7	Processor 2	Full Height	Full Height	x8	x16
Riser 3A	Slot 8	Processor 2	Full Height	Full Height	x16	x16

NOTE:

The expansion card slots are not hot-swappable.

The following table provides guidelines for installing cards to ensure proper and mechanical fit. The expansion cards with the highest priority should be installed first using the slot priority indicated. All the other expansion cards should be installed in the card priority and slot priority order.

Table 5. No riser configurations

Card type	Slot priority	Maximum number of cards
NDC	NDC Slot	1
PERC	3,1,2	1
GFX/GPU Compute(DW)	1,4,8	3
GFX(FH/SW)	1,4,8,2,5,7	Up to 6
GFX(LP)	6	1
PCIe SSD(LP)-Zoom 2	6	1
PCIe SSD(FH)-Zoom 2	1,2,3,4,5,7,8	1



Card type	Slot priority	Maximum number of cards
PCIe SSD (FH)-Zoom 4	1,4,8	2(*see Note 7)
Teradici(P25) (LP)	6	1
Teradici(P25 or P45) (FH)	1,2,4,5,7,8	2
Serial (FH)	1,2,4,5,7,8	1
Serial (LP)	6	1
Audio (FH)	1,2,4,5,7,8	1
Audio (LP)	6	1

PCIe Cards		PERC H130	PERC H730P	PERC H730P	nVidia GTX1000	nVidia P4000	FirePro W5100 / WX P3000	nVidia P5000	nVidia P4000	Nvidia P6000 FH	Nvidia P6000 LP	Radeon WX 7100	nVidia P5000	nVidia P4000	WX P4000	WX P4000	NV5310	Zoom2 LP	Zoom2 FH	Zoom4 LP	Zoom4 FH	Teradici P25 LP	Teradici P25 FH	Teradici P45 FH	Serial FH	Serial LP	Audio FH	Audio LP	Intel(R) Gigabit EP 1250+ 6/10G	Intel(R) Gigabit EP 1250+ 6/10G	Intel(R) Ethernet 10G EP X720/X730 10G
Type	Storage	Storage	Storage	PSGA	SHEGA	SHEGA	HEGA	MIRGAH	ELGA	ELGA	MIRGAH	MIRGAL	ELGA	ELGA	ELGA	ULGA	SSD	SSD	SSD	AIC	AIC	AIC	AIC	AIC	AIC	AIC	AIC	COMM	COMM	COMM	
Width	x8	x8	x8	x16	x16	x16	x16	x16	x16	x16	x16	x16	x16	x16	x8	x8	x16	x8	x16	x16	x16	x16	x16	x16	x16	x16	x16	x16	x16	x16	x16
Gen	2 or 3	2 or 3	2 or 3	3	3	3	3	3	3	3	3	3	3	3	3	3	2	2	2	3	3	1	1	1	1	1	1	1	2	2	
Power	23w	23w	23w	235w	250w	275w	180W	105W	40w	40w	150w	75W	40w	50W	50W	19.5w	25w	25w	30w	13w	13w	20w	7w	7w	7w	7w	7w	7w	7w	7w	
GPU power draw/req				X	X	X	X	X	X	X	X	X	X	X	X	X															
Interface				DP, DVI-D	DP, DVI-D	mDP	DP, DVI-D	DP	mDP	mDP	DP	DP	mDP	mDP	mDP	DP															
Supported OS	All	W7 only	W10/Linux	All	All	All	All	All	All	All	All	All	All	All	All	All	All	All	All	All	All	All	All	All	All	All	All	All	All	All	
Max Allowed	1	1	1	3	3	3	3	4	6	1	4	6	6	1	6	1	1	1	2	1	3	2	1	1	1	1	1	1	1	1	
100 NDC	NDC Slot	1																													
200 PERC																															
300 GFX/GPU Compute (DW)																															
400 GFX (FH/SW)																															
500 GFX (LP)																															
600 PCIe SSD (LP) - Zoom 2																															
600 PCIe SSD (FH) - Zoom 2																															
700 PCIe SSD (FH) - Zoom 4																															
800 Teradici (P25) (LP)																															
900 Teradici (P25 or P45) (FH)																															
1000 Serial (FH)																															
1100 Serial (LP)																															
1200 Audio (FH)																															
1300 Audio (LP)																															

- Notes:**
- Cards should be installed in the system, starting with the Card priority, then the slot priority. The first open slot priority should be used.
 - Low profile (LP), Half-Height cards can only be installed in Slot 6.
 - Slots 4, 5, 7, 8 require that CPU2 be installed in the system.
 - Any cards > 75W require one or more external power cables to be installed (power cables are included in base system BOM).
 - Graphics cards are of equal priority to each other. For multiple GPU card configs, cards must be matched (all same model).
 - nVidia GPU's using SLI must reside in slots 4 and 7 with a 2nd CPU installed. An SLI cable must also be installed.
 - Zoom4 - Dual Zoom4 requires dual microprocessor, and both Zoom cards must be populated on CPU2 (slots 4 & 8).

	Risers							
	Slot 1	Slot 2	Slot 3	Slot 4	Slot 5	Slot 6	Slot 7	Slot 8
RS1C - Bay 1 (right hand bay)	x16 FH/LP/DW	x8 FH/LP	x8 FH/LP	x16 FH/LP/DW				
RS2A - Bay 2 (center bay)				x16 FH/LP/DW	x8 LP			
RS3A - Bay 4 (left hand bay)						x8 FH/LP	x16 FH/LP/DW	
Associated CPU	CPU1			CPU2	CPU1		CPU2	
Slot Power	225w + 23w	75w + 23w	75w	225w + 23w	75w	225w + 23w	75w + 23w	

All Slots PCIe Gen3

NOTE:

- Cards should be installed in the system, starting with the Card priority, then the slot priority. The first open slot priority should be used.
- Low profile (LP), Half-Height cards can only be installed in Slot 6.
- Slots 4, 5, 7, 8 require that CPU2 be installed in the system.
- Any cards > 75 W require one or more external power cables to install (power cables are included in base system BOM).
- Graphics cards are of equal priority to each other. For multiple GPU card configs, cards must be matched (all same model).
- Nvidia GPU's using SLI must reside in slots 4 and 7 with a 2nd processor installed. An SLI cable must also be installed.
- Zoom4 - Dual Zoom4 requires dual microprocessor, and both Zoom cards must be populated on CPU2 (slots 4 & 8).
- No Teradici P25 or P45 in slot 3



System specifications

Topics:

- [System specifications](#)
- [Memory specifications](#)
- [Video specifications](#)
- [Audio specifications](#)
- [Network specifications](#)
- [Card Slots](#)
- [Storage specifications](#)
- [External connectors](#)
- [Power specifications](#)
- [Physical specifications](#)
- [Environmental specifications](#)

System specifications

Feature	Specification
Processor type	Intel Xeon Processor Scalable Family <ul style="list-style-type: none"> · Intel Xeon Platinum 81xx Processor · Intel Xeon Gold 61xx Processor · Intel Xeon Gold 51xx Processor · Intel Xeon Silver 41xx Processor · Intel Xeon Bronze 31xx Processor
Total cache	Up to 38.5 MB

Memory specifications

Features	Specifications
Type	DDR4 RDIMM ECC
Maximum Frequency	2666 MHz
Speed	2666 MHz
Connectors	24 DIMM Slots (12 per CPU)
DIMM capacities	4 GB, 8 GB, 16 GB, 32 GB, 64 GB, 128 GB  NOTE: Six channel memory up to 1.5 TB 2666 MHz DDR4 ECC memory per CPU with select CPU SKUs..
Minimum memory	16 GB (2x8 GB) i.e. 2 DIMMs per CPU



Features Specifications

Maximum memory 3 TB

 **NOTE: Up to 3 TB with select CPU SKUs**

Video specifications

Features Specifications

Graphic cards

- Radeon Pro WX 9100
- NVIDIA Quadro GP100
- NVIDIA Quadro P6000
- NVIDIA Quadro P5000
- Radeon Pro WX 7100
- Radeon Pro WX 5100
- Radeon Pro WX 4100
- NVIDIA Quadro P4000
- NVIDIA Quadro P2000
- Radeon Pro WX 3100
- Radeon Pro WX 2100
- NVIDIA Quadro P1000
- NVIDIA Quadro P600
- NVIDIA Quadro P400
- NVIDIA NVS 310
- NVIDIA NVS 315

Audio specifications

Features Specifications

Type High Definition Audio Codec (2 Channel)

Controller Integrated Realtek ALC3234

Internal Speaker 2W

Power Rating

Internal microphone support no

Network specifications

Features Specifications

Integrated Intel i219 and i210 Gigabit Ethernet controllers with Intel Remote Wake UP, PXE and Jumbo frames support.

Network adaptor 2 (Optional)

- Intel i210 10/100/1000 single port PCIe (Gen 3 x1) gigabit network card.
- Intel X550-T2 10GbE dual port PCIe (Gen 3 x4) network card.
- Aquantia AQN-108 2.5Gbit/5Gbe single port PCIe (Gen3 x4) network card.

Card Slots

Features	Specifications
Type	PCIe Gen 3
Slots	<ul style="list-style-type: none">· two PCIe Gen 3 x16· two PCIe Gen 3 x16 (enabled with 2nd CPU)· one PCIe Gen 3 x8 (open ended connector)· one PCIe Gen 3 x16 (wired as x4)· one PCIe Gen 3 x16 (wired as x1)

Storage specifications

Features	Specifications
Externally Accessible	DVD-ROM; DVD+/-RW Optional 5.25" bay devices: BD, DVD+/-RW
Internally Accessible	<ul style="list-style-type: none">· M.2 NVMe PCIe SSDs—Up to 8* x 1TB drives on 2 Dell Precision Ultra-Speed Drive Quad x16 cards. Requires dual CPU config· Front FlexBay M.2 NVMe PCIe SSDs—Up to 4* x 1TB drives, 2 drives per CPU. Requires dual CPU config· Up to 8 x 3.5" (or 2.5") SATA Drives· Up to 10 x 3.5" (or 2.5") SATA/SAS Drives with optional controller

External connectors

Features	Specifications
Audio	<ul style="list-style-type: none">· Rear—1 x Audio Line out· Rear—1 x Audio Line in/Microphone· Front—1 x Universal Audio Jack
Network	Rear—2 x RJ45 Network ports
Serial port	Rear—1 x Serial port
USB	<ul style="list-style-type: none">· Front—2 x USB 3.1 Gen 1 and 2 x USB 3.1 Gen 1 Type-C (1 with PowerShare)· Rear—6 x USB 3.1 Gen 1
PS2	<ul style="list-style-type: none">· Rear—1 x Keyboard· Rear—1 x Mouse

Power specifications

Features	Specifications
Voltage	Input voltage 100VAC - 240VAC



Features	Specifications
Wattage	<ul style="list-style-type: none"> 1400W at 181VAC - 240VAC 1100W at 100VAC - 180VAC

Physical specifications

Features	Specifications
Height	433mm
Width	218mm
Depth	566mm
Weight (Minimum)	With front bezel <ul style="list-style-type: none"> Min configuration 20.4 kg Typical configuration 24.3 kg Max configuration 33.1 kg

Environmental specifications

Temperature	Specifications
Operating	5 °C to 35 °C (41 F to 95 °F)
	 NOTE: * Starting at 5000 ft, the maximum operating ambient temperature is derated by 1 C (1.8 F) per 1000 ft up to 10,000 ft.
Storage	-40 °C to 65 °C(-40 F to 149 F)
Relative humidity (maximum)	Specifications
Operating	8% to 85% (non-condensing)
Storage	5% to 95% (non-condensing)
Maximum vibration	Specifications
Operating	0.52 Grms, 5 to 350 Hz
Storage	2.0 Grms, 5 to 500 Hz
Maximum Shock	Specifications
Operating	40 G half-sine 2.5 ms pulse
Storage	105 G half-sine 2.5 ms pulse

System Setup

Topics:

- General options
- System configuration
- Video
- Security
- Secure boot
- Performance
- Power management
- POST behavior
- Virtualization support
- Maintenance
- System logs
- Engineering configurations
- Updating the BIOS in Windows
- System and setup password

General options

Table 6. General options



Option	Description
System Information	<p>This section lists the primary hardware features of your computer.</p> <ul style="list-style-type: none"> • System Information • Memory Configuration • Processor Information • Device Information • PCI Information
Boot Sequence	<p>Allows you to change the order in which the computer attempts to find an operating system.</p> <ul style="list-style-type: none"> • Diskette Drive • USB Storage Device • CD/DVD/CD-RW Drive • Onboard NIC • Internal HDD
Boot List Option	<p>Allows you to change the boot list option.</p> <ul style="list-style-type: none"> • Legacy • UEFI



Option	Description
Advanced Boot Options	Allows you to Enable Legacy Option ROMs <ul style="list-style-type: none"> • Enable Legacy Option ROMs—Default • Enable Attempt Legacy Boot
Date/Time	Allows you to set the date and time. The changes to the system date and time take effect immediately.
UEFI Boot Path Security	Allows you to control whether the system prompts the user to enter the Admin password when booting to a UEFI boot path. Click one of the following options: <ul style="list-style-type: none"> • Always, Except Internal HDD—Default • Always • Never

System configuration

Table 7. System Configuration

Option	Description
Integrated NIC	Allows you to configure the integrated network controller. The options are: <ul style="list-style-type: none"> • Enable UEFI Network Stack • Disabled <p> NOTE: You can use the Disabled option, only if Active Management Technology (AMT) option is disabled.</p> <ul style="list-style-type: none"> • Enabled • Enabled w/PXE (Default)
Integrated NIC 2	Allows you to configure the integrated network controller. The options are: <ul style="list-style-type: none"> • Enabled (Default) • Enabled w/PXE <p> NOTE: This feature is supported only on Tower 7920.</p>
UEFI Network Stack	Allows pre-OS and early OS networking features to use any enabled NICs. <ul style="list-style-type: none"> • Enabled UEFI Network Stack <p>This option is set by default.</p>
Serial Port	Identifies and defines the serial port settings. You can set the serial port to: <ul style="list-style-type: none"> • Disabled • COM1 (Default) • COM2 • COM3 • COM4

Option	Description
	<p>NOTE: The operating system may allocate resources even if the setting is disabled.</p>
SATA Operation	
7910 Tower	<p>Allows you to configure the internal SATA hard-drive controller. The options are:</p> <ul style="list-style-type: none"> • Disabled • AHCI • RAID-On (Default) <p>NOTE: SATA is configured to support RAID mode.</p>
Drives	
7910 Tower	<ul style="list-style-type: none"> • SATA-0 • SATA-1 • SATA-2 • SATA-3 • SATA-4 • SATA-5 • SATA-6 • SATA-7 • SATA-8 <p>Default Setting: All drives are enabled.</p> <p>NOTE: If the hard drives are connected to a RAID controller card, the hard drives will display {none} in all the fields. The hard drives can be seen in the RAID controller card BIOS.</p>
PCIe Drives	<p>Allows the enabling of Front PCIe attached Ports.</p> <ul style="list-style-type: none"> • MiniSAS PCIe SSD-0 • MiniSAS PCIE SSD-1 • MiniSAS PCIe SSD-2 • MiniSAS PCIE SSD-3 <p>Default Setting: All drives are enabled.</p>
SMART Reporting	<p>This field controls if the hard drive errors for the integrated drives are reported during system startup. This technology is part of the SMART (Self Monitoring Analysis and Reporting Technology) specification.</p> <ul style="list-style-type: none"> • Enable SMART Reporting - This option is disabled by default.
USB Configuration	<p>Allows you to enable or disable the internal USB configuration. The options are:</p> <ul style="list-style-type: none"> • Enable Boot Support • Enable Front USB Ports • Enable internal USB ports • Enable rear USB Ports



Option	Description
HDD Fans	Allows you to control the HDD fans. Default Setting: depends on the system configuration
Audio	Allows you enable or disable the audio feature. <ul style="list-style-type: none"> • Enable Audio (Default)
Memory Map IO above 4GB	Allows you enable or disable Memory Map IO above 4GB. <ul style="list-style-type: none"> • Memory Map IO above 4GB - This option is disabled by default.
Thunderbolt	Allows you to enable or disable Thunderbolt device support capability. <ul style="list-style-type: none"> • Enabled • Disabled (Default)
Miscellaneous devices	Allows you to enable or disable various on board devices. <ul style="list-style-type: none"> • Enable Secure Digital (SD) Card (Default On) • Secure Digital (SD) Card Read Only Mode • Secure Digital (SD) Card Boot
Intel VMD Technology	Allows you to enable or disable VMD on the front PCIe bays. <ul style="list-style-type: none"> • PCIe0 • PCIe1 • PCIe0_CPU1 • PCIe1_CPU1 <p>Default Setting: All options are enabled.</p> <p>Allows you to disable VMD for the PCIe Slots.</p> <ul style="list-style-type: none"> • Auto (Default On) • Disabled

Video

Table 8. Video

Option	Description
Primary Video Slot	Allows you to configure primary boot video device. The options are: <ul style="list-style-type: none"> • Auto (Default) • SLOT 1 • SLOT 2: VGA Compatible • SLOT 3 • SLOT 4 • SLOT 5 • SLOT 6 • SLOT1_CPU2: VGA Compatible • SLOT2_CPU2

Security

Table 9. Security

Option	Description
Strong Password	Allows you to enforce the option to always set strong passwords. Default Setting: Enable Strong Password is not selected.
Password Configuration	You can define the length of your password. Min = 4 , Max = 32
Password Bypass	Allows you to enable or disable the permission to bypass the System password, when it is set. The options are: <ul style="list-style-type: none"> • Disabled (Default) • Reboot bypass
Password Change	Allows you to enable the disable permission to the System passwords when the administrator password is set. Default Setting: Allow Non-Admin Password Changes is selected
UEFI Capsule Firmware Updates	Allows you to update the system BIOS via UEFI capsule update packages. <ul style="list-style-type: none"> • Enable UEFI Capsule Firmware Updates This option is set by default.
TPM Security	Allows you to enable the Trusted Platform Module (TPM) during POST. Default Setting: The option is disabled.
Computrace (R)	Allows you to activate or disable the optional Computrace software. The options are: <ul style="list-style-type: none"> • Deactivate (Default) • Disable • Activate
Chassis Intrusion	Allows you to control the chassis intrusion feature. Click one of the following options: <ul style="list-style-type: none"> • Disabled—Default • Enabled • On-Silent
CPU XD Support	Allows you to enable the Execute Disable mode of the processor. <ul style="list-style-type: none"> • Enable CPU XD Support (Default)
OROM Keyboard Access	Allows you to determine whether users are able to enter Option ROM Configuration screens via hotkeys during boot. The options are: <ul style="list-style-type: none"> • Enable (Default) • One Time Enable • Disable
Admin Setup Lockout	Allows you to prevent users from entering Setup when an administrator password is set. <ul style="list-style-type: none"> • Enable Admin Setup Lockout



Option	Description
	Default Setting: The option is disabled.

Secure boot

Table 10. Secure Boot

Option	Description
Secure Boot Enable	Allows you to enable or disable the Secure Boot Feature. The options are: <ul style="list-style-type: none"> • Disabled (Default) • Enabled
Expert Key Management	Allows you to enable or disable Custom Mode Key Management. <ul style="list-style-type: none"> • Disabled (Default)

Performance

Table 11. Performance

Option	Description
Multi Core Support	This field specifies whether the processor will have one or all cores enabled. The performance of some applications will improve with the additional cores. This option is enabled by default. Allows you to enable or disable multi-core support for the processor. The options are: <ul style="list-style-type: none"> • All (Default) • 1 • 2 • 3 • 4 • 5 • 6 • 7 • 8 <p>NOTE:</p> <ul style="list-style-type: none"> • The options displayed could be different depending on the installed processor(s). • The options depend on the number of cores supported by the installed processor (All, 1, 2, N-1 for N-Core Processors)
Intel SpeedStep	Allows you to enable or disable the Intel SpeedStep feature. Default Setting: Enable Intel SpeedStep
C States	Allows you to enable or disable the additional processor sleep states.

Option	Description
	Default Setting: Enabled
Intel TurboBoost	Allows you to enable or disable the Intel TurboBoost mode of the processor. Default Setting: Enable Intel TurboBoost
Hyper-Thread Control	Allows you to enable or disable the HyperThreading in the processor. Default Setting: Enabled
Cache Prefetch	Default Setting: Enable Hardware Prefetch and Adjacent Cache Line Prefetch
Dell Reliable Memory Technology (RMT)	Allows you to identify and isolate memory errors in system RAM.. Default Setting: Enable Dell Reliable Memory Technology (RMT)
System Isochronous Mode	Allows you to enable or disable this mode to reduce latency of memory transactions at the expense of bandwidth. : Click one of the options: <ul style="list-style-type: none"> • Disabled(Default) • Enabled
RAS Support	Allows you to report or log errors caused by memory failures, the PCIe failures, CPU failures. The options are: <ul style="list-style-type: none"> • Enable on Memory modules • Enable on PCIe modules • Enable on CPU modules <p>The options are not set by default.</p>

Power management

Table 12. Power Management

Option	Description
AC Recovery	Specifies how the computer will respond when AC power is applied after a AC power loss. You can set the AC Recovery to: <ul style="list-style-type: none"> • Power Off (Default) • Power On • Last Power State
Auto On Time	Allows you to set the time at which the computer must turn on automatically. The options are: <ul style="list-style-type: none"> • Disabled (Default) • Every Day • Weekdays • Select Days
Deep Sleep Control	Allows you to define the controls when Deep Sleep is enabled. <ul style="list-style-type: none"> • Disabled (Default)



Option	Description
	<ul style="list-style-type: none"> Enabled in S5 only Enabled in S4 and S5
USB Wake Support	<p>Allows you to enable USB devices to wake the system from standby.</p> <ul style="list-style-type: none"> Enable USB Wake Support <p>Default Setting: The option is disabled.</p>
Wake on LAN	<p>This option allows the computer to power up from the off state when triggered by a special LAN signal. Wake-up from the Standby state is unaffected by this setting and must be enabled in the operating system. This feature only works when the computer is connected to AC power supply.</p> <ul style="list-style-type: none"> Disabled - Does not allow the system to power on by special LAN signals when it receives a wake-up signal from the LAN or wireless LAN. LAN Only - Allows the system to be powered on by special LAN signals. LAN with PXE Boot - Allows the system to power on and immediately boot to PXE when it receives a wake-up packet sent to the system in either the S4 or S5 state. <p>This option is Disabled by default.</p>
Block Sleep	<p>Allows you to block entering to sleep (S3 state) in OS Environment.</p> <p>Default Setting: Disabled</p>

POST behavior

Table 13. POST Behavior

Option	Description
Numlock LED	Specifies if the NumLock function can be enabled when the system boots. This option is enabled by default.
Keyboard Errors	Specifies whether keyboard related errors are reported when it boots. This option is enabled by default.
Fastboot	<p>Allows you to speed up the boot process by bypassing some compatibility steps. The options are:</p> <ul style="list-style-type: none"> Minimal Thorough - This option is enabled by default. Auto

Virtualization support

Table 14. Virtualization Support

Option	Description
Virtualization	<p>This option specifies whether a Virtual Machine Monitor (VMM) can utilize the additional hardware capabilities provided by Intel Virtualization technology.</p> <ul style="list-style-type: none"> Enable Intel Virtualization Technology - This option is enabled by default.
VT for Direct I/O	Enables or disables the Virtual Machine Monitor (VMM) from utilizing the additional hardware capabilities provided by Intel Virtualization technology for direct I/O.

Option	Description
	<ul style="list-style-type: none"> • Enable VT for Direct I/O - This option is enabled by default.
Trusted Execution	<p>Allows you to specify whether a Measured Virtual Machine Monitor (MVMM) can utilize the additional hardware capabilities provided by Intel Trusted Execution Program.</p> <ul style="list-style-type: none"> • Trusted Execution - This option is disabled by default.

Maintenance

Table 15. Maintenance

Option	Description
Service Tag	Displays the service tag of your computer.
Asset Tag	Allows you to create a system asset tag if an asset tag is not already set. This option is not set by default.
SERR Messages	Controls the SERR message mechanism. This option is not set by default. Some graphics cards require that the SERR message mechanism be disabled.

System logs

Table 16. System Logs

Option	Description
BIOS events	<p>Displays the system event log and allows you to clear the log.</p> <ul style="list-style-type: none"> • Clear Log

Engineering configurations

Table 17. Engineering configurations

Option	Description
ASPM	<ul style="list-style-type: none"> • Auto (Default) • L1 Only • Disabled • L0s and L1 • L0s Only
Pcie LinkSpeed	<ul style="list-style-type: none"> • Auto (Default) • Gen1 • Gen2 • Gen3

Updating the BIOS in Windows

It is recommended to update your BIOS (System Setup), when you replace the system board or if an update is available. For laptops, ensure that your computer battery is fully charged and connected to a power outlet



NOTE: If BitLocker is enabled, it must be suspended prior to updating the system BIOS, and then re-enabled after the BIOS update is completed.

- 1 Restart the computer.
- 2 Go to **Dell.com/support**.
 - Enter the **Service Tag** or **Express Service Code** and click **Submit**.
 - Click **Detect Product** and follow the instructions on screen.
- 3 If you are unable to detect or find the Service Tag, click **Choose from all products**.
- 4 Choose the **Products** category from the list.

NOTE: Choose the appropriate category to reach the product page

- 5 Select your computer model and the **Product Support** page of your computer appears.
- 6 Click **Get drivers** and click **Drivers and Downloads**.
The Drivers and Downloads section opens.
- 7 Click **Find it myself**.
- 8 Click **BIOS** to view the BIOS versions.
- 9 Identify the latest BIOS file and click **Download**.
- 10 Select your preferred download method in the **Please select your download method below** window, click **Download File**.
The **File Download** window appears.
- 11 Click **Save** to save the file on your computer.
- 12 Click **Run** to install the updated BIOS settings on your computer.
Follow the instructions on the screen.

NOTE: It is recommended not to update the BIOS version for more than three revisions. For example: If you want to update the BIOS from 1.0 to 7.0, then install version 4.0 first and then install version 7.0.

Updating BIOS on systems with bitlocker enabled

CAUTION: If BitLocker is not suspended before updating the BIOS, the next time you reboot the system it will not recognize the BitLocker key. You will then be prompted to enter the recovery key to progress and the system will ask for this on each reboot. If the recovery key is not known this can result in data loss or an unnecessary operating system re-install. For more information on this subject, see Knowledge Article: <http://www.dell.com/support/article/us/en/19/SLN153694/updating-bios-on-systems-with-bitlocker-enabled>

Updating your system BIOS using a USB flash drive

If the system cannot load into Windows but there is still a need to update the BIOS, download the BIOS file using another system and save it to a bootable USB Flash Drive.

NOTE: You will need to use a bootable USB Flash drive. Please refer to the following article for further details: <http://www.dell.com/support/article/us/en/19/SLN143196/how-to-create-a-bootable-usb-flash-drive-using-dell-diagnostic-deployment-package--ddd->

- 1 Download the BIOS update .EXE file to another system.
- 2 Copy the file e.g. O9010A12.EXE onto the bootable USB Flash drive.
- 3 Insert the USB Flash drive into the system that requires the BIOS update.
- 4 Restart the system and press F12 when the Dell Splash logo appears to display the One Time Boot Menu.
- 5 Using arrow keys, select **USB Storage Device** and click Return.
- 6 The system will boot to a Diag C:\> prompt.
- 7 Run the file by typing the full filename e.g. O9010A12.exe and press Return.
- 8 The BIOS Update Utility will load, follow the instructions on screen.



Figure 1. DOS BIOS Update Screen

Updating the Dell BIOS in Linux and Ubuntu environments

If you want to update the system BIOS in a Linux environment such as Ubuntu, see <http://www.dell.com/support/article/us/en/19/SLN171755/updating-the-dell-bios-in-linux-and-ubuntu-environments>.

Flashing the BIOS from the F12 One-Time boot menu

Updating your system BIOS using a BIOS update .exe file copied to a FAT32 USB key and booting from the F12 one time boot menu.

BIOS Update

You can run the BIOS update file from Windows using a bootable USB key or you can also update the BIOS from the F12 One-Time boot menu on the system.

Most Dell systems built after 2012 have this capability and you can confirm by booting your system to the F12 One-Time Boot Menu to see if BIOS FLASH UPDATE is listed as a boot option for your system. If the option is listed, then the BIOS supports this BIOS update option.

NOTE: Only systems with BIOS Flash Update option in the F12 One-Time Boot Menu can use this function.

Updating from the One-Time Boot Menu

To update your BIOS from the F12 One-Time boot menu, you will need:

- USB key formatted to the FAT32 file system (key does not have to be bootable)
- BIOS executable file that you downloaded from the Dell Support website and copied to the root of the USB key
- AC power adapter connected to the system
- Functional system battery to flash the BIOS

Perform the following steps to execute the BIOS update flash process from the F12 menu:

CAUTION: Do not power off the system during the BIOS update process. Powering off the system could make the system fail to boot.

- 1 From a power off state, insert the USB key where you copied the flash into a USB port of the system .
- 2 Power on the system and press the F12 key to access the One-Time Boot Menu, Highlight BIOS Flash Update using the arrow keys then press **Enter**.



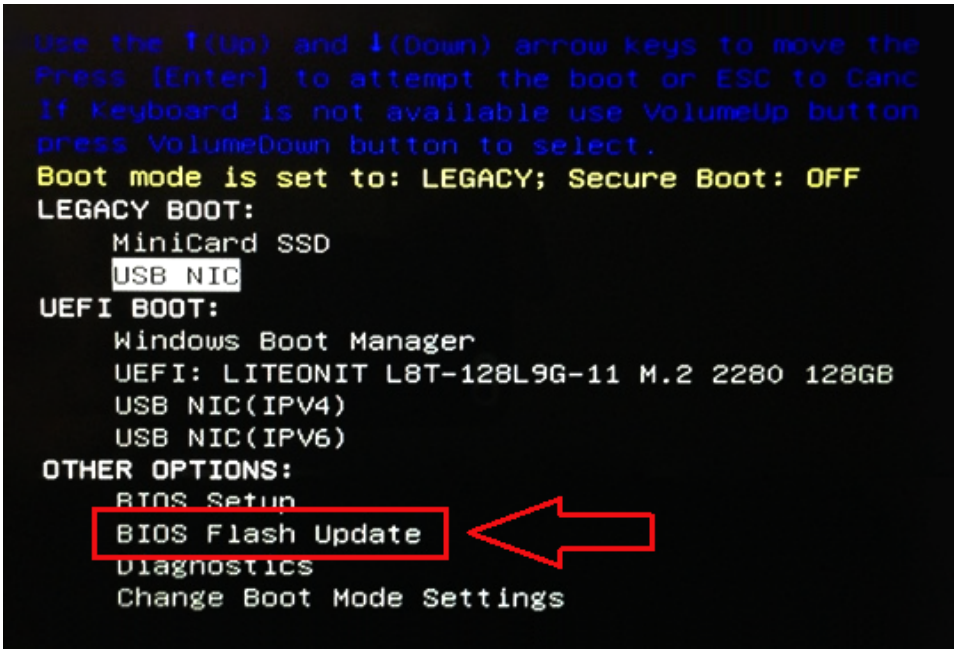

- 3 The Bios flash menu will open then click the browse button.

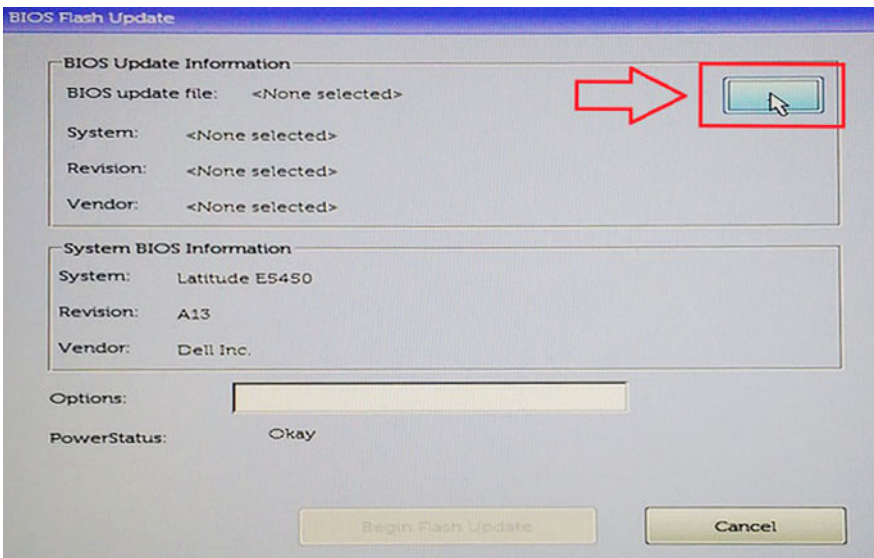

- 4 The E5450A14.exe file is shown as an example in the following screenshot. The actual file name may vary.

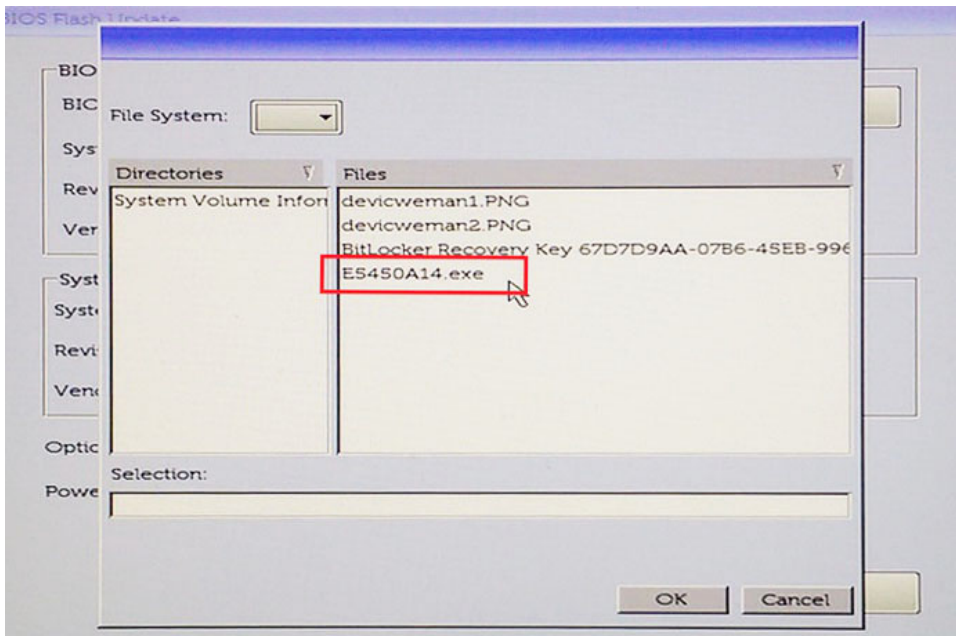

- 5 Once the file is selected, it will show in the file selection box and you can click the OK button to continue.

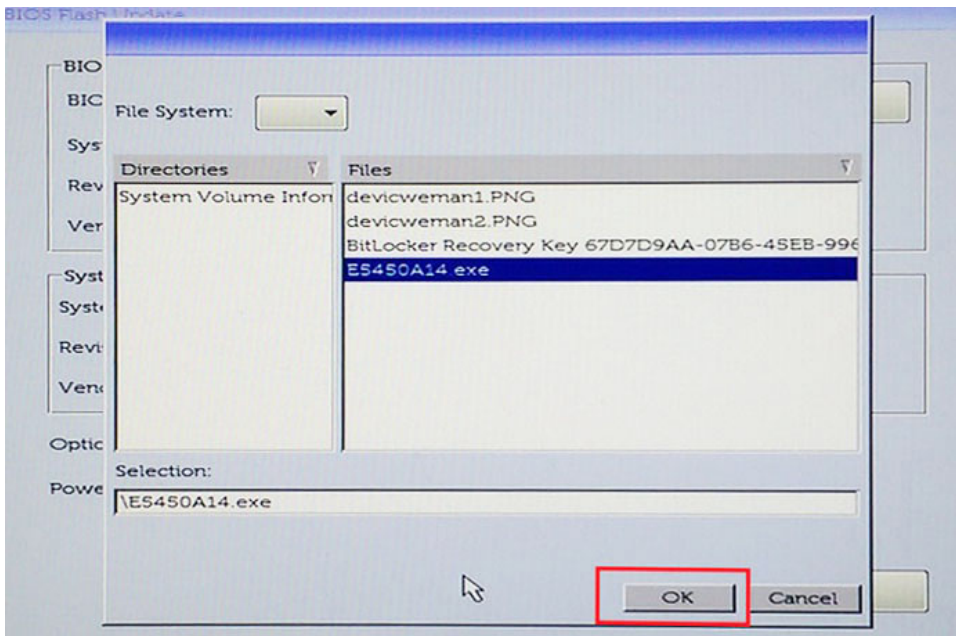

- 6 Click the **Begin Flash Update** button.

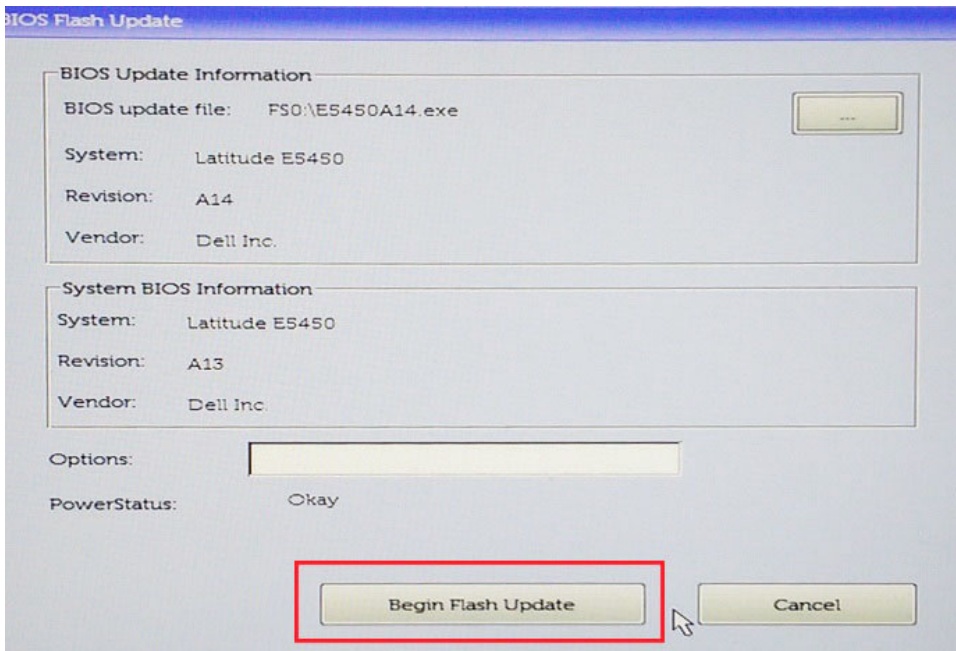

- 7 A warning box is displayed asking you if you want to proceed. Click the Yes button to begin the flash.

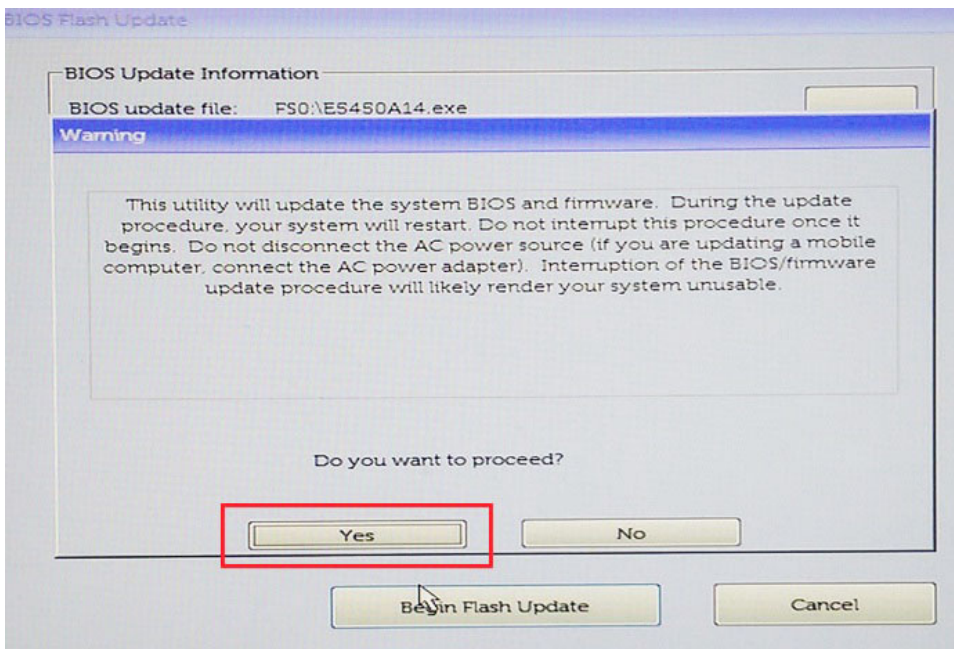

- 8 At this point the BIOS flash will execute, the system will reboot and then the BIOS flash will start and a progress bar will show the progress of the flash. Depending on the changes included in the update, the progress bar may go from zero to 100 multiple times and the flash process could take as long as 10 minutes. Generally this process takes two to three minutes.

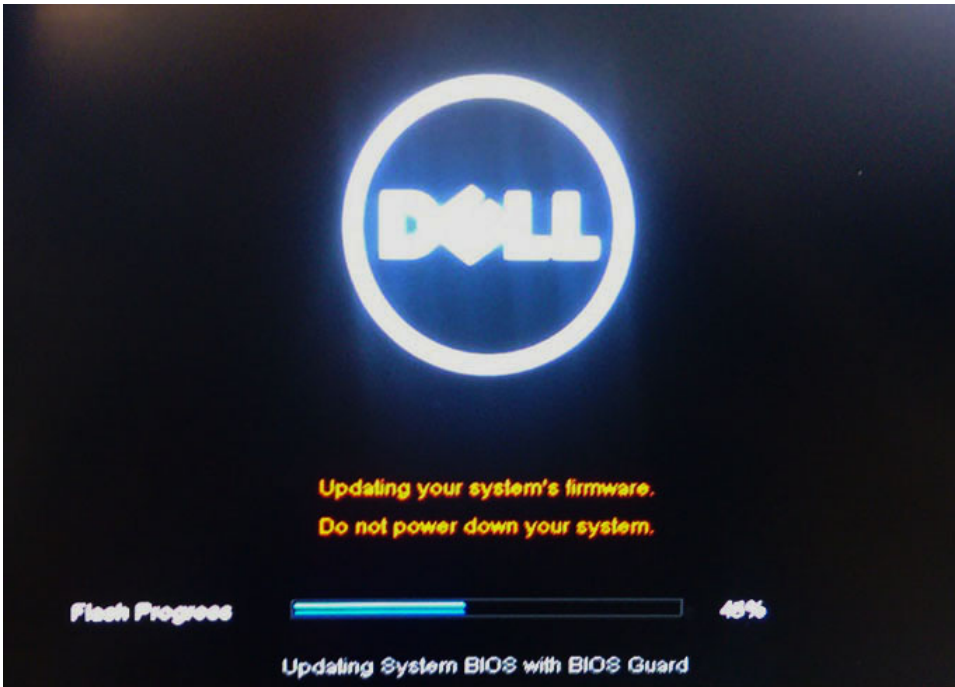

9 Once complete, the system will reboot and the BIOS update process is completed.

System and setup password

Table 18. System and setup password

Password type	Description
System password	Password that you must enter to log on to your system.
Setup password	Password that you must enter to access and make changes to the BIOS settings of your computer.

You can create a system password and a setup password to secure your computer.

⚠ CAUTION: The password features provide a basic level of security for the data on your computer.

⚠ CAUTION: Anyone can access the data stored on your computer if it is not locked and left unattended.

🔒 NOTE: System and setup password feature is disabled.

Assigning a system password and setup password

You can assign a new **System Password** only when the status is in **Not Set**.

To enter the system setup, press F2 immediately after a power-on or re-boot.

- 1 In the **System BIOS** or **System Setup** screen, select **Security** and press Enter.
The **Security** screen is displayed.
- 2 Select **System Password** and create a password in the **Enter the new password** field.
Use the following guidelines to assign the system password:
 - A password can have up to 32 characters.
 - The password can contain the numbers 0 through 9.



- Only lower case letters are valid, upper case letters are not allowed.
 - Only the following special characters are allowed: space, ("), (+), (,), (-), (.), (/), (:), ([), (\), (]), (`).
- 3 Type the system password that you entered earlier in the **Confirm new password** field and click **OK**.
 - 4 Press Esc and a message prompts you to save the changes.
 - 5 Press Y to save the changes.
The computer reboots.

Deleting or changing an existing system setup password

Ensure that the **Password Status** is Unlocked (in the System Setup) before attempting to delete or change the existing System and/or Setup password. You cannot delete or change an existing System or Setup password, if the **Password Status** is Locked. To enter the System Setup, press F2 immediately after a power-on or reboot.

- 1 In the **System BIOS** or **System Setup** screen, select **System Security** and press Enter.
The **System Security** screen is displayed.
- 2 In the **System Security** screen, verify that **Password Status** is **Unlocked**.
- 3 Select **System Password**, alter or delete the existing system password and press Enter or Tab.
- 4 Select **Setup Password**, alter or delete the existing setup password and press Enter or Tab.

NOTE: If you change the System and/or Setup password, re-enter the new password when promoted. If you delete the System and/or Setup password, confirm the deletion when promoted.

- 5 Press Esc and a message prompts you to save the changes.
- 6 Press Y to save the changes and exit from System Setup.
The computer reboot.

Software

This chapter details the supported operating systems along with instructions on how to install the drivers.

Topics:

- Supported operating system
- Downloading drivers
- Chipset driver
- Graphics controller driver
- USB drivers
- Network drivers
- Audio drivers
- Ports
- Storage controller drivers
- Other drivers

Supported operating system

Table 19. Operating systems

Windows 10	<ul style="list-style-type: none"> • Factory installed Windows 10 Pro—64-bit • Factory installed Win 10 Enterprise—64 bit
Windows 7	Windows 7 Pro—64-bit
Linux	<ul style="list-style-type: none"> • RHEL 7.3 • Ubuntu 16.04 • NeoKylin v6.0

Downloading drivers

- 1 Turn on the computer.
- 2 Go to **Dell.com/support**.
- 3 Click **Product Support**, enter the Service Tag of your system, and then click **Submit**.

 **NOTE: If you do not have the Service Tag, use the auto detect feature or manually browse for your system model.**

- 4 Click **Drivers and Downloads**.
- 5 Select the operating system installed on your system.
- 6 Scroll down the page and select the driver to install.
- 7 Click **Download File** to download the driver for your system.
- 8 After the download is complete, navigate to the folder where you saved the driver file.
- 9 Double-click the driver file icon and follow the instructions on the screen.



Chipset driver

Verify if the Intel chipset and Intel Management Engine Interface drivers are already installed in the computer.

- System devices
 - ACPI Fixed Feature Button
 - ACPI Module Device
 - Advanced programmable interrupt controller
 - Composite Bus Enumerator
 - Direct memory access controller
 - High Definition Audio Controller
 - High Definition Audio Controller
 - Intel(R) C620 series chipset CSME: IDE Redirection - A1BC
 - Intel(R) C620 series chipset LPC Controller - A1C1
 - Intel(R) C620 series chipset MROM 0 - A1EC
 - Intel(R) C620 series chipset MROM 1 - A1ED
 - Intel(R) C620 series chipset PCI Express Root Port #1 - A190
 - Intel(R) C620 series chipset PCI Express Root Port #8 - A197
 - Intel(R) C620 series chipset PMC - A1A1
 - Intel(R) C620 series chipset SMBus - A1A3
 - Intel(R) C620 series chipset SPI Controller - A1A4
 - Intel(R) C620 series chipset Thermal Subsystem - A1B1
 - Intel(R) Management Engine Interface
 - Intel(R) Xeon(R) processor P family/Core i7 CBDMA Registers - 2021
 - Intel(R) Xeon(R) processor P family/Core i7 CBDMA Registers - 2021
 - Intel(R) Xeon(R) processor P family/Core i7 CBDMA Registers - 2021
 - Intel(R) Xeon(R) processor P family/Core i7 CBDMA Registers - 2021
 - Intel(R) Xeon(R) processor P family/Core i7 CBDMA Registers - 2021
 - Intel(R) Xeon(R) processor P family/Core i7 CBDMA Registers - 2021
 - Intel(R) Xeon(R) processor P family/Core i7 CBDMA Registers - 2021
 - Intel(R) Xeon(R) processor P family/Core i7 CBDMA Registers - 2021
 - Intel(R) Xeon(R) processor P family/Core i7 CBDMA Registers - 2021
 - Intel(R) Xeon(R) processor P family/Core i7 CHA Registers - 2057
 - Intel(R) Xeon(R) processor P family/Core i7 CHA Registers - 2054
 - Intel(R) Xeon(R) processor P family/Core i7 CHA Registers - 2056
 - Intel(R) Xeon(R) processor P family/Core i7 CHA Registers - 2055
 - Intel(R) Xeon(R) processor P family/Core i7 CHA Registers - 208E

Graphics controller driver

Verify if the graphics controller driver is already installed in the computer.

- Display adapters
 - NVIDIA NVS 310

USB drivers



Verify if the USB drivers are already installed in the computer.



- ▼  Universal Serial Bus controllers
 -  Generic SuperSpeed USB Hub
 -  Generic USB Hub
 -  Intel(R) USB 3.0 eXtensible Host Controller - 1.0 (Microsoft)
 -  USB Composite Device
 -  USB Mass Storage Device
 -  USB Root Hub (xHCI)

Network drivers

This system comes with both LAN and WiFi drivers and is able to detect the LAN and WiFi without going through the drivers installation.

- ▼  Network adapters
 -  Intel(R) Ethernet Connection (3) I219-LM
 -  Intel(R) I210 Gigabit Network Connection



Audio drivers

Verify if audio drivers are already installed in the computer.

- ▼  Sound, video and game controllers
 -  High Definition Audio Device
 -  Realtek Audio
 - ▼  Audio inputs and outputs
 -  Speakers / Headphones (Realtek Audio)





Ports

Verify if the drivers for the ports are already installed in the computer.

- ▼  Ports (COM & LPT)
 -  Communications Port (COM1)
 -  Intel(R) Active Management Technology - SOL (COM3)

Storage controller drivers

Verify if the storage controller drivers are installed in the computer.

- ▼  Storage controllers
 -  Intel(R) C600+/C220+ series chipset SATA RAID Controller
 -  Intel(R) C600+/C220+ series chipset sSATA AHCI Controller
 -  Microsoft Storage Spaces Controller

Other drivers

This section lists driver details for all the other components in the Device Manager.

Security device drivers

Verify if the security device drivers are installed in the computer.



- Security devices
 - Trusted Platform Module 1.2

Software device drivers

Verify if the software device drivers are installed in the computer.

- Software devices
 - Microsoft Device Association Root Enumerator
 - Microsoft GS Wavetable Synth

Human Interface Devices

Verify if the Human Interface device drivers are installed in the computer.

- Human Interface Devices
 - USB Input Device

Portable Devices

Verify if the portable device drivers are installed in the computer.

- Portable Devices
 - D:\

Troubleshooting

The following section describes common troubleshooting steps that can be performed to resolve certain problems on your computer.

Dell Enhanced Pre-Boot System Assessment — ePSA diagnostic 3.0

You can invoke the ePSA diagnostics by performing either of the following steps:

- Press the F12 key when the system boots and choosing **Diagnostics** option.
- Press Fn+PWR when the system boots.

For more details, see [Dell EPSA Diagnostic 3.0](#).

Running the ePSA diagnostics

- 1 Power-on the computer.
- 2 As the computer boots, press the F12 key as the Dell logo appears.
- 3 On the boot menu screen, select the **Diagnostics** option.
- 4 Click the arrow key at the bottom left corner.
Diagnostics front page is displayed.
- 5 Press the arrow in the lower-right corner to go to the page listing.
The items detected are listed.
- 6 To run a diagnostic test on a specific device, press Esc and click **Yes** to stop the diagnostic test.
- 7 Select the device from the left pane and click **Run Tests**.
- 8 If there are any issues, error codes are displayed.
Note the error code and validation number and contact Dell.

Testing memory using ePSA

- 1 Turn on or restart your system.
- 2 Perform one of the following actions after the Dell logo is displayed:
 - With keyboard — Press **F12**.

The PreBoot System Assessment (PSA) starts on your system.

NOTE: If you wait too long and the operating system logo appears, continue to wait until you see the desktop. Turn off the laptop and try again.



Preboot blinking power button codes

Table 20. Power button LED state

Power Button LED State	Description
Off	Power is Off. LED is blank.
Blinking Amber	Initial State of LED at power up. See the table below for Blinking Amber pattern diagnostic suggestions and possible failures.
Blinking White	System is in a low power state, either S1 or S3. This does not indicate a fault condition.
Solid Amber	The second state of the LED at power up, indicates that the POWER_GOOD signal is active and it is probable that the power supply is fine.
Solid White	System is in S0 state. This is the normal power states of a functioning machine. The BIOS will turn the LED to this states to indicate it has started fetching op-codes.

Table 21. Diagnostic Indicator table

Power Light: Amber-White Blinking	Amber/White Blinking Pattern	Problem Description	Suggested Resolution
1-1	1 amber blink followed by a short pause, 1 white blink, long pause, then repeats	Faulty System board	To troubleshoot the issue with system board, contact Tech support.
1-2	1 amber blink followed by a short pause, 2 white blinks, long pause, then repeats	Bad system board, Power Supply or Power Supply cabling	<ul style="list-style-type: none"> If you can assist to troubleshoot, narrow down the issue with PSU BIST Test, reseal cable. If nothing works, contact Tech Support
1-3	1 amber blink followed by a short pause, 3 white blinks, long pause, then repeats	Bad system board, Memory or Processor	<ul style="list-style-type: none"> If you can assist to troubleshoot, narrow down the issue by reseating memory and swapping a known good memory if available. If nothing works, contact Tech Support
2-1	2 amber blinks followed by a short pause, 1 white blink, long pause, then repeats	Bad Processor	<ul style="list-style-type: none"> CPU configuration activity is in progress or a CPU failure was detected. Contact Tech Support If you can assist to troubleshoot, narrow down the issue by ensuring CPU 0 is installed, CPU0 and CPU1 is an identical matching pair and swapping a known good CPUs if available.



Power Light: Amber-White Blinking	Amber/White Blinking Pattern	Problem Description	Suggested Resolution
			<ul style="list-style-type: none"> If nothing works, contact Tech Support
2-2	2 amber blinks followed by a short pause, 2 white blinks, long pause, then repeats	Motherboard: BIOS ROM failure	<ul style="list-style-type: none"> System is in Recovery Mode. Flash latest BIOS version. If problem persists, contact Tech Support
2-3	2 amber blinks followed by a short pause, 3 white blinks, long pause, then repeats	No Memory	<ul style="list-style-type: none"> If customer can assist to troubleshoot, narrow down the issue by removing the memory module one by one to determine which one failed and swapping to a known good memory if available to confirm. Contact Tech Support
2-4	2 amber blinks followed by a short pause, 4 white blinks, long pause, then repeats	Memory/RAM failure	<ul style="list-style-type: none"> If customer can assist to troubleshoot, narrow down the issue by removing the memory module one by one to determine which one failed and swapping to a known good memory if available to confirm. Contact Tech Support
2-5	2 amber blinks followed by a short pause, 5 white blinks, long pause, then repeats	Invalid memory installed	<ul style="list-style-type: none"> Memory subsystem configuration activity is in progress. Memory modules have been detected but appear to be incompatible or in an invalid configuration. If customer can assist to troubleshoot, narrow down the issue by removing one by one the memory on motherboard to determine which one failed. Contact Tech Support.
2-6	2 amber blinks followed by a short pause, 6 white blinks, long pause, then repeats	Motherboard: Chipset	<ul style="list-style-type: none"> Fatal system board failure detected. If customer can assist to troubleshoot, narrow down the issue by removing one by one the component on motherboard to determine which one failed. If you identified any of the components failed, replace the Component. Contact Tech Support.
3-2	3 amber blinks followed by a short pause, 2 white blinks, long pause, then repeats	PCI Device or Video	<ul style="list-style-type: none"> PCI device configuration activity is in progress or PCI device failure was detected. If you can assist to troubleshoot, narrow down



Power Light: Amber-White Blinking	Amber/White Blinking Pattern	Problem Description	Suggested Resolution
			<p>the issue by reseating PCI card and removing one by one to determine which card failed.</p> <ul style="list-style-type: none"> • Contact Tech Support.
3-3	3 amber blinks followed by a short pause, 3 white blinks, long pause, then repeats	BIOS Recovery 1	<ul style="list-style-type: none"> • System is in Recovery Mode. • Flash latest BIOS version. If problem persists, contact Tech Support
3-4	3 amber blinks followed by a short pause, 4 white blinks, long pause, then repeats	BIOS Recovery 2	<ul style="list-style-type: none"> • System is in Recovery Mode. • Flash latest BIOS version. If problem persists, contact Tech Support
4-5	4 amber blinks followed by a short pause, 5 white blinks, long pause, then repeats	PCIe Add-in Card population issue	<ul style="list-style-type: none"> • PCI device is installed on CPU1 slot and CPU1 is not installed. • If you can assist to troubleshoot, move all PCIe card in CPU1 slot to CPU0 slot. An alternative would be install an identical CPU as CPU0 to CPU1 socket. • Contact Tech Support
4-6	4 amber blinks followed by a short pause, 6 white blinks, long pause, then repeats	RAID Volume degraded	<ul style="list-style-type: none"> • RAID volume is degraded. • If you can assist to troubleshoot, us F12 menu to enter Device Configuration tab. Rebuild the RAID volume if possible • Contact Tech Support.
4-7	4 amber blinks followed by a short pause, 7 white blinks, long pause, then repeats	System Side cover is missing	<ul style="list-style-type: none"> • System side cover(either left or right) is missing. • Unplug power, Install back all side covers back to the chassis and plug in power. • Contact Tech Support.

Contacting Dell

NOTE: If you do not have an active Internet connection, you can find contact information on your purchase invoice, packing slip, bill, or Dell product catalog.

Dell provides several online and telephone-based support and service options. Availability varies by country and product, and some services may not be available in your area. To contact Dell for sales, technical support, or customer service issues:

- 1 Go to **Dell.com/support**.
- 2 Select your support category.
- 3 Verify your country or region in the **Choose a Country/Region** drop-down list at the bottom of the page.
- 4 Select the appropriate service or support link based on your need.

